

# **ADVANCE LIFTS**

*Series 6000 Owners Manual*



## **NOTICE**

This manual is an important document. Keep it with the machine or located where readily available to operators and maintenance personnel for reference purposes.

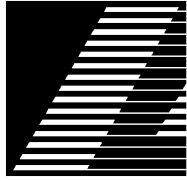

# **ADVANCE LIFTS**

---

## INSTALLATION, OPERATION AND MAINTENANCE MANUAL FOR THE FOLLOWING DOCK LIFT MODEL NUMBERS

Throughout this manual, units are referred to by series. Each series has special installation, maintenance and operational requirements.

### 6000 Series Lifts

6568	65610	6868	68710	68810
610610	610710	610810	610612	610712
610812	612610	612710	612810	612612
612712	612812	615610	615710	615810
615612	615712	215812		

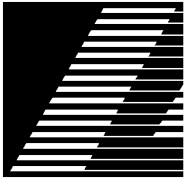

# ADVANCE LIFTS

## Dock Lift Installation, Operation, and Maintenance Manual

In any correspondence with your distributor or the factory you will need the following information:

Model Number \_\_\_\_\_ Serial Number \_\_\_\_\_

Installation location: \_\_\_\_\_

\_\_\_\_\_

\_\_\_\_\_

### NOTICE

At Initial Installation, determine proper motor/pump rotation by starting the motor in very short intervals to prevent permanent pump damage. Running the pump backwards will damage it. See the Installation Instructions, Section 4, for proper procedure.

Distributor Information: \_\_\_\_\_

\_\_\_\_\_

\_\_\_\_\_

\_\_\_\_\_

**Advance Lifts, Inc.**  
**701 S. Kirk Road**  
**St. Charles, IL 60174-3428**  
**Toll Free 1-800-843-3625**  
**Sales Fax 1-630-584-9405**  
**Parts and Service Fax 1-630-584-6837**  
**E-mail: [Parts@advancelifts.com](mailto:Parts@advancelifts.com)**

\*Advance Lifts, Inc. furnishes one manual with each unit. Additional manuals are available at \$25.00 each.

## SECTION 2 INDEX & INTRODUCTION

Identification .....	Section 1
Index & Introduction .....	Section 2
*Responsibilities of Owners/Users .....	Section 3
*Installation Instructions .....	Section 4
*Operating Instructions .....	Section 5
*Maintenance Instructions .....	Section 6
Power Unit Assemblies .....	Section 7
Hydraulic Details .....	Section 8
General hydraulic information	
Schematics	
Fluid recommendations & seal compatibility	
Pressure information for hoses & pipes	
Component information	
Cylinder repair procedures	
Electrical Details .....	Section 9
Schematics	
Controller specifications	
Component information	
Wire size charts	
Identification and Label Placement .....	Section 10
Troubleshooting Hints .....	Section 11
Warranty .....	Section 12

## INTRODUCTION

Congratulations, the equipment that you have purchased is of the highest quality. Your Advance Lift will provide you with many years of trouble free service in return for the minimal maintenance described in this manual.

Please be sure that no individual is allowed to operate the lift until they have been fully familiarized with operating instructions in this manual. Also insure that at least one person at the lift site is familiar with the maintenance section of this manual and is assigned responsibility for doing the maintenance on a regular basis.

Please note that the lift has a metal nameplate attached to it that contains information such as the model number, capacities, and the serial number. Do not remove the nameplate. Be sure that no operator ever exceeds the capacities shown on the nameplate or they may cause damage to the lift or injure personnel. Also, be sure to have the serial number of the lift handy if you have to call the factory. That serial number identifies your specific lift and will allow factory personnel to give you the most thorough and timely assistance possible.

This manual is under constant review and we would appreciate any constructive suggestions that may enhance its usefulness. Please send your suggestions to Advance Lifts, Inc Attn: Service Manager

Thank you for purchasing our product.

\*Mandatory reading before attempting installation.

## SECTION 3. RESPONSIBILITIES OF OWNERS & USERS

**Basic Principles:** Owners/users shall apply sound principles of safety, training, inspection, maintenance, and expected operating environment.

It shall be the responsibility of the owner/user to advise the manufacturer where deflection may be critical to the application.

**Manuals:** Owners/users shall keep and maintain a copy of the operating and maintenance manual(s) and ensure its availability to operating and maintenance personnel.

**Inspection and Maintenance:** It shall be the responsibility of the users to inspect and maintain the industrial scissors lift as required to ensure proper operation. The frequency of inspection and maintenance shall be based upon the manufacturer's recommendations and be compatible with operating conditions and the severity of the operating environment.

Industrial scissors lifts that are not in proper operating condition shall be immediately removed from service until repaired. Maintenance and repairs shall be made by a qualified person and the repairs shall be in conformance with the manufacturer's recommendations.

**Maintenance Safety Precautions:** Before adjustments and repairs are started on an industrial scissors lift, the following precautions shall be taken as applicable:

1. Remove the load from the platform.
2. Lower platform to the full down position, if possible or secure by maintenance device and/or blocking as described by the manufacturer to prevent unintended platform movement.
3. Relieve system pressure from all circuits before loosening or removing any components.
4. All controls in the "off" position and all operating features secured from inadvertent motion by brakes, blocks, or other means.
5. Disconnect power and follow established owner/user lockout/tag out policies.
6. Follow precautions and directions as specified by the manufacturer.

**Replacement Parts:** When parts or components are replaced, they shall be replaced with parts or components approved by the original manufacturer of the industrial scissors lift.

**Maintenance Training:** The owner/user shall ensure only qualified personnel inspect and maintain the industrial scissors lift in accordance with the sections: Inspection and Maintenance, Replacement Parts and Operator Training and the manufacturer's recommendations as described in the maintenance manual.

**Operator Training:** An owner/user, who directs or authorizes an individual to operate an industrial scissors lift, shall ensure that the individual has been:

1. Trained in accordance with the manufacturer's operating manual.
2. Made aware of the responsibilities of operators as outlined under the Operators Section of this manual.
3. Retrained, if necessary, based on the owners/user's observation and evaluation of the operator.

**Modifications:** Modifications and additions shall not be performed without the manufacturer's prior written approval. Where such authorization is granted, capacity, operation, and maintenance instruction plates, tags, or decals shall be changed accordingly.

SECTION 3 (Continued). RESPONSIBILITIES OF OWNERS & USERS  
Responsibility of Operators

**Basic Principles:** Operators shall apply sound principles of safety and good judgment in the application and operation of the scissors lift, with consideration given to its intended use and expected operating environment. Since the operator is in direct control of the industrial scissors lift, conformance with good safety practices is the responsibility of the operator. The operator shall make decisions on the consideration for the fact that his or her own safety as well as the safety of other personnel on or near the scissors lift is dependent on those decisions.

**General Training:** Only personnel who have received general instructions regarding the inspection, application and operation of industrial scissors lifts, including recognition and avoidance of hazards associated with their operation, shall operate an industrial scissors lift. Such topics covered shall include, but not necessarily be limited to, the following issues and requirements:

1. A pre-start inspection
2. Responsibilities associated with problems or malfunctions affecting the operation of the industrial scissors lift
3. Factors affecting stability
4. The purpose of placards and decals
5. Workplace inspection
6. Safety rules and regulations
7. Authorization to operate
8. Operator warnings and instructions
9. Actual operation of the industrial scissors lift. Under the direction of a qualified person, the trainee shall operate the industrial scissors lift for a sufficient period of time to demonstrate proficiency in actual operation of the industrial scissors lift.

**Prestart Inspection:** Before use each day or at the beginning of each shift, the industrial scissors lift shall be given a visual inspection and functional test including but not limited to the following:

1. Operating and emergency controls
2. Safety devices
3. Air or hydraulic system leaks
4. Electrical cables and wiring harness
5. Loose or missing parts
6. Wheels and casters
7. Nameplates, precautionary and instructional markings and/or labeling
8. Guardrail system
9. Items specified by the manufacturer

**Problem or Malfunctions:** Any problems or malfunctions that affect the safety of operations shall be repaired prior to the use of the industrial scissors lift.

**Before Operations:** The operator shall:

1. Read and understand the manufacturer's operating instruction(s) and user's safety rules or have them explained
2. Understand all labels, warnings, and instructions displayed on the industrial scissors lift or have them explained

SECTION 3 (Continued). RESPONSIBILITIES OF OWNERS & USERS  
Responsibility of Operators

**Workplace Inspections:** Before the industrial scissors lift is used and during use, the operator shall check the area in which the industrial scissors lift is to be used for possible hazards such as, but not limited to:

1. Bumps, floor obstructions and uneven surfaces
2. Overhead obstructions and electrical hazards
3. Presence of unauthorized persons
4. Other possible unsafe conditions as noted in the operating manual.

**Operator Warnings and Instructions:** The operator shall ensure the operation of the industrial scissors lift is in compliance with the following:

1. **Slope.** The industrial scissors lift shall only be operated on flat and level surfaces.
2. **Guardrail system.** Guardrails shall be installed and positioned, and access gates or openings shall be secured per the manufacturer's instructions.
3. **Distribution of load.** The load and its distribution on the platform and any platform extension(s) shall be in accordance with the manufacturer's rated capacity for that specific configuration.
4. **Maintaining overhead clearance.** The operator shall ensure that adequate clearance is maintained from overhead obstructions and energized electrical conductors and parts.
5. **Point of Operation.** The operator shall not place any part of their body under the platform.
6. **Personnel footing.** Personnel shall maintain firm footing on dock lifts and work access lifts while working thereon. Climbing by occupants on the guardrail system is prohibited. The use of planks, ladders, or any other devices on the platform for achieving additional height is prohibited.
7. **Precaution for moving equipment.** When other moving equipment or vehicles are present, special precautions shall be taken to comply with the safety standards established for the workplace.
8. **Reporting problems or malfunctions.** The operator shall immediately report to a supervisor any problem(s) or malfunction(s) that become evident during operation. The operator shall ensure all problems and malfunctions that affect the safety of operations are repaired prior to continued use.
9. **Capacity limitation.** Rated capacity shall not be exceeded when loads are transferred to the platform at any level.
10. **Work area.** The operator shall ensure the area surrounding the industrial scissors lift is clear of personnel and equipment before lowering the platform.
11. **Battery charging.** Batteries shall be charged in strict accordance with the lift manufacturer's instructions.
12. **Securing the industrial scissors lift.** The operator shall comply with the means and procedures provided to protect against use by an unauthorized person(s).
13. **Altering safety devices.** Safety devices shall not be altered or disabled.
14. **Modifications.** Modifications or alterations of an industrial scissors lift or the fabrication and attaching of frameworks or the mounting of attachments for holding tools or materials onto the platform or the guardrail system shall only be accomplished with prior written permission of the manufacturer.
15. **Assistance to the operator.** If an operator encounters any suspected malfunction or any hazard or potentially unsafe condition relating to capacity, intended use or safe operation the operator shall cease operation of the industrial scissors lift and request further instruction from the owner/user.
16. **Problems or malfunctions.** Any problem(s) or malfunction(s) that affect the safety of operations shall be repaired prior to the use of the industrial scissors lift.

## SECTION 4. INSTALLATION INSTRUCTIONS

### Equipment and Supplies Required:

1. Equipment to maneuver the Advance Lift into position. Nylon slings are preferred, but padded alloy chains will also work as rigging.
2. Material for shimming and grouting, and anchor bolts. We recommend “Rawl-Stud Wedge Anchors”, “Wej-It” or equivalent bolts in the 5/8” x 6” size for the model 6568 and 1” x 9” size for all other models. The studs must be embedded at least 4 ½” into the concrete.
3. Electrical fused disconnect (if required), refer to local electrical codes.
4. Wire and electrical fittings for the branch circuit, 6000 series units are factory pre-wired ready to plug into the branch circuit.
5. Standard hand tools for electrical work and hydraulic maintenance.
6. A heavy pry bar for shifting the equipment and a drill for installing the lag down studs.
7. Maintenance device, this is supplied by Advance Lifts on all units. Check the maintenance section of this manual for proper usage of each style of maintenance device.

### Installation Procedure:

1. Read the Installation, Operating, and Maintenance instructions completely before attempting installation. You may also find it helpful to read the remaining sections of the manual for a better understanding of how the equipment works.
2. 6000 Series units are prewired from the factory.  
**Be sure that you have correct motor rotation at start up!** Continued operation of a hydraulic pump in reverse rotation will destroy it! If the unit does not immediately rise when pressing the up button, change motor rotation by swapping any two of the power wires. Single-phase motors are set at the factory.

#### NOTICE

**This unit has a traveling electrical cord. The cord must be protected to keep it from being damaged by the lift.**

#### WARNING

**A DAMAGED ELECTRICAL CORD IS A SERIOUS HAZARD. FAILURE TO PROTECT THE ELECTRICAL CORD COULD RESULT IN SERIOUS INJURY OR DEATH**



## SECTION 4. (CONTINUED) INSTALLATION INSTRUCTIONS

### Installation Instructions:

4. Figure out the proper orientation of the lift. 6000 Series lifts are typically configured with a ramp and bridge. Ramps are for lift to ground transfer only and the bridge is for truck to lift transfer only. 6000 Series lifts used in face of dock applications are required to maintain a 4" gap between the vertical dock wall and the lift for proper clearance and to eliminate a shear hazard.

 **WARNING**

**THIS LIFT HAS NO TOE GUARD PROTECTION. MAINTAIN PROPER CLEARANCE BETWEEN ANY VERTICAL SURFACE AND THE LIFT TO AVOID A SHEAR HAZARD. FAILURE TO FOLLOW THIS WARNING COULD RESULT IN SERIOUS INJURY**

5. Once positioned, you may now break the shipping restraints (steel banding).
6. Once the lift is properly positioned you may begin the lag down procedure.
7. Raise the unit and position the maintenance device as shown in the maintenance section of this manual (pages 6-3 through 6-5). Lower the unit onto the maintenance devices and press the down button for an extra 10 seconds to relieve all hydraulic pressure. Drill the lag down holes and set the lag bolts. **NOTE: Check the unit for side to side level and then shim or grout the base frame for continuous support. The shimming should enhance the match between the platform and the surrounding surfaces when fully lowered, but not at the expense of side to side levelness. A slight slope from clevis end to roller end is not a problem, but side to side slope will cause premature wear on all the moving parts of the lift. Tighten the lag bolts.**
8. Operate the equipment through several cycles, holding the down button an extra 20 seconds after the lift is fully lowered to bleed air from the cylinders.
9. Adjust travel limit switch, if required.
10. Raise the unit one final time, install the maintenance device, and thoroughly clean the entire area. Due to the rigors of transportation, hydraulic fittings may loosen, check all hydraulic fittings for leaks and tighten as needed.
11. Meet with the facility manager or maintenance foreman and turn over this maintenance manual with the reminder that no one should be allowed to operate the unit unless they are familiar with the operating instructions. Show them the maintenance device, guardrails, entry chains and/or gates. Point out the metal nametag on the unit with the serial number and capacity ratings. Make it clear that some specific person in their organization must be charged with responsibility for the maintenance of the unit and if they have no further questions, lower the unit and consider your job complete.

## 6000 - SERIES CONCRETE PAD DIAGRAM

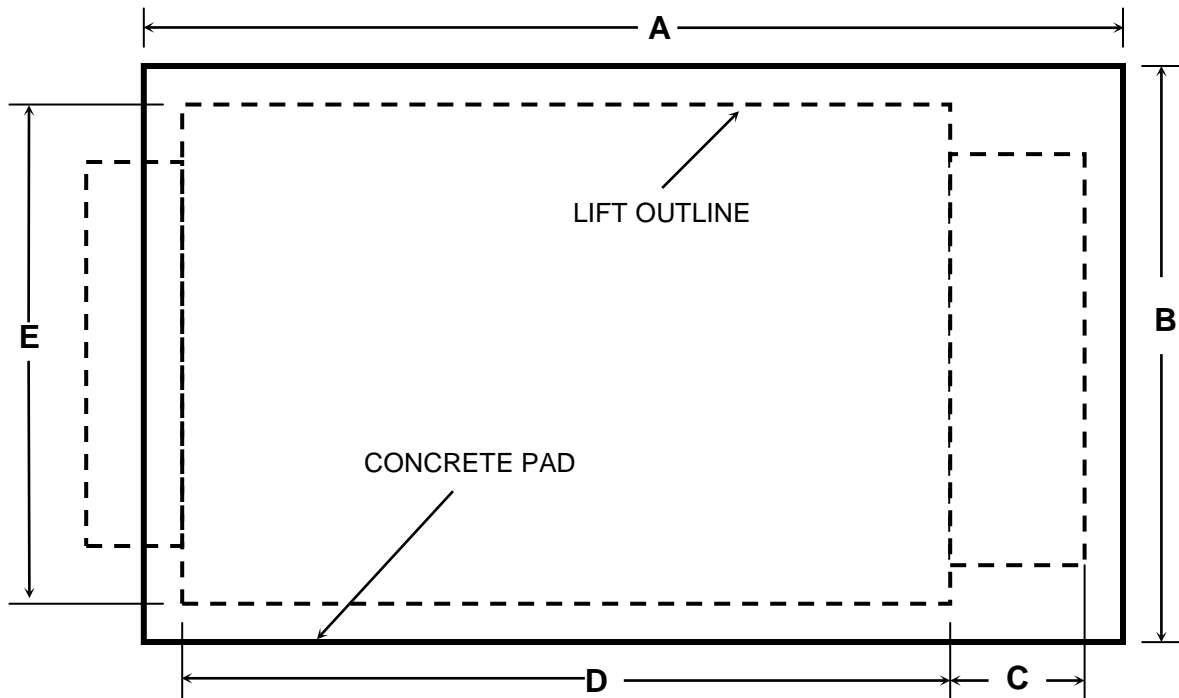

*MODEL NUMBER	A = CONCRETE PAD LENGTH	B = CONCRETE PAD WIDTH	C = RAMP LENGTH	D = LIFT LENGTH	E = LIFT WIDTH
6568	145"	96"	30"	96"	72"
65610	169"	96"	30"	120"	72"
6868	157"	96"	42"	96"	72"
68610	181"	96"	42"	120"	72"
68710	191"	110"	42"	120"	84"
68810	181"	102"	42"	120"	96"
610610	181"	96"	42"	120"	72"
610710	181"	110"	42"	120"	84"
610810	181"	102"	42"	120"	96"
610612	205"	96"	42"	144"	72"
610712	205"	110"	42"	144"	84"
610812	205"	102"	42"	144"	96"
612610	181"	96"	42"	120"	72"
612710	181"	110"	42"	120"	84"
612810	181"	102"	42"	120"	96"
612612	205"	96"	42"	144"	72"
612712	205"	110"	42"	144"	84"
612812	205"	102"	42"	144"	96"
615610	181"	96"	42"	120"	72"
615710	181"	110"	42"	120"	84"
615810	181"	102"	42"	120"	96"
615612	205"	96"	42"	144"	72"
615712	205"	110"	42"	144"	84"
615812	205"	102"	42"	144"	96"

## SECTION 4. (CONTINUED) INSTALLATION INSTRUCTIONS

### **Bill of Materials\***

1. One (1) Advance Superdok Model Number\_\_\_\_\_.
2. One (1) electric disconnect switch for 2 or 5 horsepower motor.
3. One (1) plug receptacle.
4. Concrete anchor bolts and material for shimming and/or grouting.

\*Seller furnishes items 1 – 4 only unless otherwise agreed to in writing.

### **Notes:**

- A. Reinforce concrete to suit local soil conditions.
- B. All concrete work is the responsibility of the owner or his agent.
- C. Concrete pad must be flat and level.
- D. All 6 – Series lifts used in face of dock applications must be held off the vertical face of the dock 4” to maintain minimum clearances.

### **Final Checks:**

1. Unit is level and all gaps in the base frame are shimmed or grouted.
2. Unit positioned so that bollards protect the unit and allow proper purchase of the bridge in the truck.
3. Unit lagged firmly in place.
4. Electrical cord protected.

## SECTION 5. OPERATING INSTRUCTIONS

Hydraulic scissors lifts have an excellent operational record overall, but as with all moving equipment they can be dangerous. Operators must use common sense and take responsibility for everyone near the lift. They must use the devices provided and be careful not to surprise anyone in the area with the movement of the lift.

### **Pre-operational checks:**

1. Check all electrical wiring and connections to be sure that they are completed properly and are operational. Make sure the electrical cord cannot interfere with the travel of the lift.
2. Check for the proper operating condition of the devices such as guardrails, entry chains, and optional equipment such as electric toe guards, warning bells, or automatic chocks.
3. Check for obstructions or debris that may interfere with the operation of the lift.
4. Be sure that all personnel in the area are well away from the lift and aware that you are about to move it.
5. Know the capacity of the lift to be sure not to overload it.

### **Test operate the equipment:**

1. Station yourself so that you always see the equipment and surrounding area when it is in operation. Never operate the equipment in the blind.
2. Raise the equipment and note that the pushbutton is a constant pressure, "dead-man" type. When you release the up or down button, the unit should stop moving immediately and maintain its elevation. If it does not, notify your maintenance personnel immediately.
3. Cycle the equipment several times to be sure that it is operating smoothly with no jerking or sudden movement. On initial start up there may be some air in the lines or the cylinders may be dry due to storage so it may take several cycles to smooth out the operation. If the operation is not smooth after several cycles, contact your maintenance personnel. If there is any evidence of binding or scraping in the operation you should immediately stop using the lift.
4. Check all guardrails, entry chains and/or gates for proper operation.
5. If you elect to test load the equipment be sure that you do not exceed the capacities shown on the nameplate. Overloading may cause structural stresses that may not show up for some time, but will diminish the life and capacity of the unit. If you have any questions about testing the unit, call the engineering department at the factory at 1-800-843-3625.

## COMPATIBLE LOADING EQUIPMENT GUIDE:

Each Advance lift is designed with a weight capacity and platform design for specific types of loading equipment. Using the wrong type of loading equipment on a given series of lifts will invite unintentional overloading. For safe operation, follow these guidelines and be careful to never exceed the nameplate.

UNIT	TYPE OF LOADING EQUIPMENT
6568 & 65610	Hand carts, four wheeled carts & manual pallet jacks.
	All of the above and small powered pallet jacks.
6868, 68610, 68710, 68810, 610610, 610710; 610810, 610612, 610712, 610812	All of the above & straddle stackers, small stand-up & sit-down rider fork trucks.
All other 6 – Series units not listed above.	All of the above & medium fork trucks.

Calculate the weight of the heaviest types of loads you expect to handle to be sure that they are within the rated capacity. Beware of surprisingly heavy materials such as liquids, grains, powder, and paper; all of which can weigh much more than you suspect because of their density.

A little effort to determine the true weight of your heaviest loads before you start to use your equipment can save damage to your equipment and possible injury to your personnel. If you discover that some loads will exceed the capacity of the unit, make arrangements to have the loads split. All operating personnel should be warned about heavy loads, warning signs should be placed in the dock lift area as a reminder.

### **Daily operation:**

1. All personnel should be required to read the entire operating instruction section of this manual prior to operating the lift.
2. Operators must know the capacity of the unit and be aware of any loads that may exceed capacity.
3. Operators must be alert to all personnel in the vicinity of the lift and avoid any surprises to these personnel in regard to movement of or the position of the lift at any time. Never operate the unit if you can not see it and the personnel around it.
4. On the first use of the lift each day, each operator should check to see that the lift is operating properly and smoothly. All guardrail and entry chains and gates should be in place and operating properly and the hinged bridge should be swung through its full arc of movement. The bridge stops should prevent the bridge from drooping more than 45 degrees below the horizontal in the forward position and the bridge should swing back 20 degrees beyond vertical toward the platform in the upright position. Any problems should be immediately reported to the maintenance personnel.

## Daily Operation (Continued)

5. This unit has a traveling electrical cord, the operator must insure that it is kept away from the lift as it rises and lowers.
6. When raising or lowering the lift, the load should be centered on the platform (that is, the load should be evenly distributed and its center of gravity should be at the center of the platform).
7. If a unit is equipped with both a hinged bridge and a hinged ramp, be sure that the operators know the difference and never use the ramp for load transfer in the raised position. The ramps are usually much longer than the bridges which means they can work as a long lever creating severe eccentric loads and they are often positioned on the weakest side of the lift for load movement in the fully lowered position only. **Use ramps in the fully lowered position only!**
8. Do not allow bridges or ramps to “free fall” from near vertical positions to the position against their hinge stops. This type of abuse will definitely cause damage to the stops, hinges, and platform edges, eventually rendering the unit unsafe. Lower ramps by hand and lower bridges to the down stop position with the restraining chains.

### Efficient lift usage:

The following procedures will help you maximize the efficient use of your lift in your loading and unloading operations.

1. First it should be noted that there is a long restraining chain on each lift that is designed to run from the hinged bridge to the guardrail post farthest away from the bridge. The purpose of this chain is to allow an operator to pull the hinged bridge back from anywhere on the platform with minimal movement, once the bridge is raised to the near vertical position by the truck bed as the lift is lowered.
2. This means that the hinged bridge only has to be manually lifted once in a loading or unloading sequence. It should be raised to the vertical standing position before the lift is raised to truck height. Once the top of the bridge is just above the truck bed height, the bridge can be pushed against the truck and allowed to cam into truck. Then when you lower the unit, the bridge is allowed to cam up on the truck bed to the near vertical position and then pulled back to a safe resting position with the chain. There is a second snap on the chain that allows you to lock the bridge in the raised position whenever the load or guardrails prevents the bridge from swinging back at least 20° beyond vertical. (See illustration at end of section.)
3. If your unit is equipped with an approach ramp, do not raise the ramp on each cycle. In fact, the ramp is to be raised only when the lift is being moved to a new location. Many of the ramps are designed with built in wheel chocks which help prevent a wheeled vehicle from rolling off the platform and only work properly when the ramp is lowered.

### How To Use Superdoks Efficiently.

Palletized Loads: One (1) man removes pallet from truck places it in storage area and returns for next pallet until truck is offloaded.

Non Palletized Loads: One (1) man in truck stacks material on pallet or 4 wheeled cart. Second (2nd) man removes pallet or cart from truck places it in storage area and returns for next load until truck is unloaded.

#### Objective

"TO FREE UP THE TRUCK AS QUICKLY AS POSSIBLE"

#### CAUTION:

With 180 Degree movement bridges exercise care in steps 5 & 7 as bridge will continue to pivot back flat on the platform.

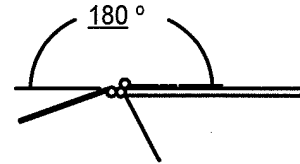

Placing Bridge in Truck With bridge folded back toward platform raise the dock lift until the top the bridge is just above the opening of the truck, push the bridge against the truck with your foot while controlling the fall with the locking chains. As the dock lift is raised, the bridge will cam over onto the truck bed and lay flat for loading and unloading.

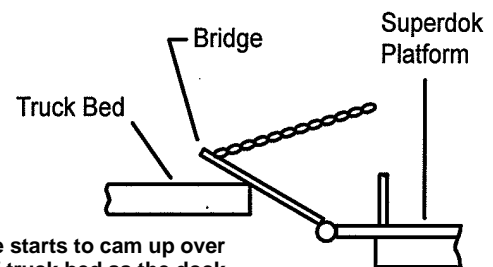

#### Removing Bridge from Truck and Securing

Begin to lower the dock lift until the bridge starts to cam up over the end of the truck bed. With foot, chain, or hand, flip bridge back toward platform. Once bridge is folded back toward platform attach retaining hook (A) to secure the bridge in place and continue lowering the unit.

If a unit has a chock ramp the chock ramp is not to be folded back during up and down unloading operations. Its normal position is extended ready for unloading at floor level. (See Section 6-1)

As required attach snap hook (A) to hold bridge upright.

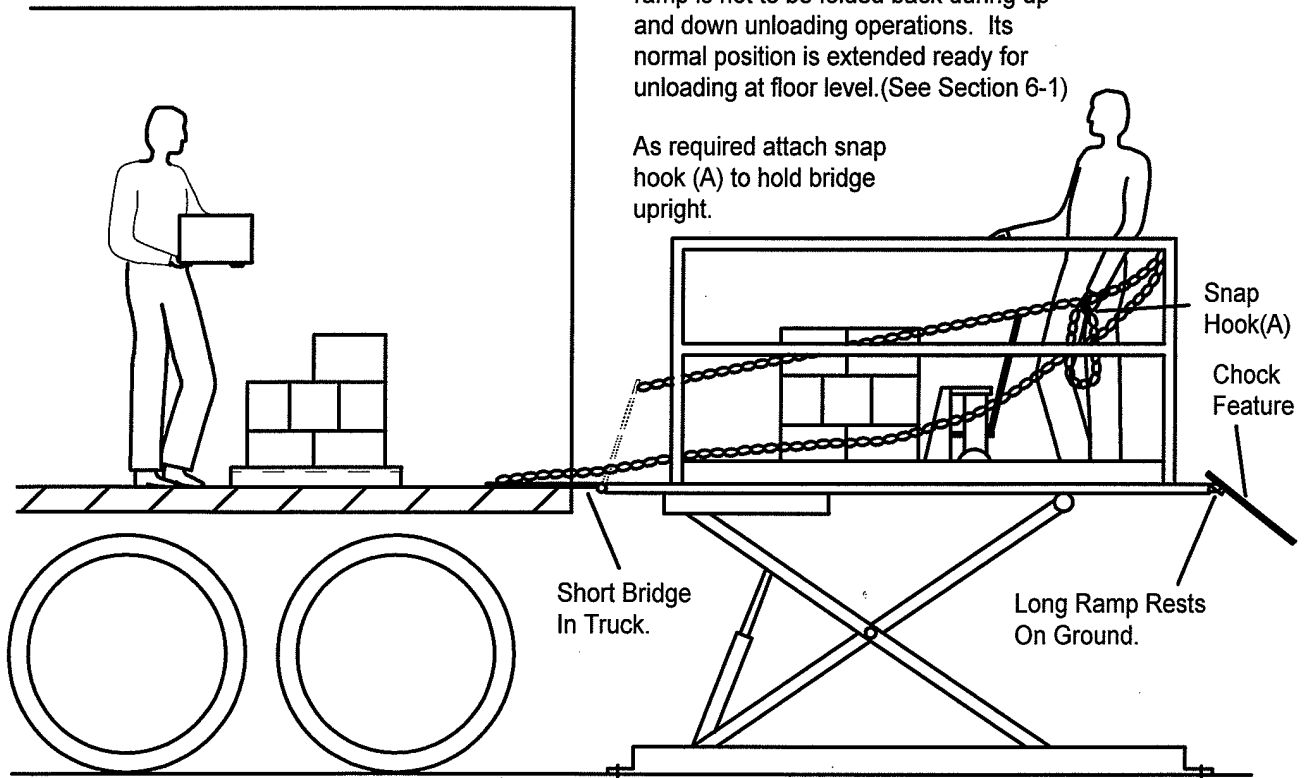

## SECTION 6. MAINTENANCE INSTRUCTIONS

The routine maintenance of this equipment is minor and consists of periodic checks.

**Weekly:** Once a week, or after repetitive operation, the lift should be raised to its full height. This will get rid of cylinder oil seepage build-up and lubricate the upper cylinder barrel.

**Monthly:** Check that the hydraulic fluid level in the reservoir is 1" to 2" from the top of the tank, depending on model, with the unit fully lowered. It is strongly urged that a maintenance log be maintained with the dates of monthly inspections, the name of the inspector and results of the inspection.

Be sure the maintenance device is properly engaged before performing maintenance checks 2 through 6 or reaching beneath a raised lift. **(Read all of section 6 for proper maintenance device procedures).**

1. Clean all debris from the vicinity of floor mounted units in order to avoid interference with the lift mechanism or rollers.
2. Check for presence and proper seating of all snap rings and clips on all axles, cylinders, and rollers.
3. Check rollers, pins and bushings for any signs of wear such as flat spots, missing fasteners, or dislodged bearing material.
4. Check the hydraulic fittings for cracks or leaks and clean up any seepage on or beneath the cylinders.
5. Check hoses and electrical lines for abrasions or other abuse and check for snug connections.
6. Operate the unit and check for any abnormal noise or vibrations.
7. Check all devices on the unit such as guardrails, entry and bridge locking chains, etc. including any options such as electric toe guards or chocks, for proper operation.
8. Check the hinged bridge to insure that its stops are not damaged, allowing it to droop more than 45 degrees below horizontal, check the hinge spools for cracks and or broken welds, be sure the bridge leans back over the platform at least 20 degrees beyond vertical.

### **Seasonal or semiannual maintenance:**

Change hydraulic fluid for ambient temperature changes if appropriate. Check the fluid reservoir to see if there is any evidence of accumulated condensation creating water contamination. The fluid will appear "milky" and light pink in color. Water accumulation will damage the hydraulic pump.



## SECTION 6. (CONTINUED)

### Maintenance Cautions:

1. Always remember that this is a piece of machinery with large moving parts that can seriously hurt you.
2. Read this manual in its entirety before attempting service work.
3. Always use the maintenance device if you are going to work on the unit in the elevated position or reach under the platform. (See the illustrations at the end of this section for proper positioning and engagement of the maintenance device.)
4. It may be necessary to bypass travel limit switches in order to properly position the maintenance device.
5. When using the maintenance device observe the following rules:
  - A. There shall be no load on the platform
  - B. The maintenance device shall be properly engaged.
  - C. Hold the down button an extra 10 seconds when lowering onto the maintenance device to be sure that all the weight of the lift is on the support.
  - D. Use shoring or blocking as a backup to the maintenance device.
  - E. Disconnect and tag the electricity to the unit to prevent accidental movement of the lift by other personnel.
  - F. Spend as little time as possible under the lift.
6. Use only replacement parts recommended by the manufacturer.
7. Do not let the equipment stay in disrepair; fix little problems while they are little problems or some of them may get severe very quickly.
8. Inspect the equipment on a regular schedule, preferably monthly.
9. Never work on the hydraulics or electrical systems unless the unit is fully lowered or properly sitting on a maintenance device.
10. Never apply a load to the equipment unless the base is continuously supported and non-portable units are securely lagged to the ground.
11. Never expect to hold leg assemblies open by simply lifting one end of a platform.
  - A. The roller end of most lifts are not gibbed or captured in any way, so lifting on the roller end simply tilts the platform.
  - B. Even if you raise the clevis end of the platform, if the base frame is not firmly lagged to the ground or held down by some other means, the legs will come up with the platform in a spongy and unpredictable manner and could cause serious injury.
  - C. The only safe way to hold a lift's legs open other than the factory designed maintenance device is to block between the clevis end of the platform and the base frame.

## Section 6. (Continued)

### Recommended Lift Blocking Procedures

#### **DANGER**

**Only authorized personnel should perform inspection or maintenance and service procedures. Unauthorized personnel attempting these procedures do so at the risk of severe injury or death.**

#### **DANGER**

**Failure to properly adhere to lift blocking procedures is to risk the sudden and uncontrolled descent of the lift during maintenance or inspection. A falling lift can cause severe injury or death.**

This procedure describes the only factory-approved method of working under a lift. Follow these instructions EVERY time you plan to reach or crawl beneath the lift to perform service or maintenance – no matter how momentary that might be.

If the factory-provided maintenance device is damaged or missing, stop immediately and consult the factory for assistance. The manufacturer is not liable for your failure to use the approved maintenance device(s) and procedures that have been provided.

1. Any load must be removed from the lift prior to engaging the maintenance device(s). These devices are designed to support an unloaded lift only. Failure to remove the load from the lift prior to blocking could cause the failure of the maintenance device(s) and allow the lift to fall unexpectedly. This can result in personal injury or death, or permanent damage to the maintenance device(s) and/or the lift.
2. Raise the lift to its fully raised position. If you do not, the maintenance device(s) may not be able to be placed properly in its/their designed blocking position.
3. Remove the maintenance device(s) from its/their storage location and place it/them into the engaged position as shown in Figures 1-9. Read and understand the specific instructions for your equipment before proceeding.
4. Lower the lift until it makes complete contact with the maintenance device(s). Re-check to ensure that all provided devices are fully and securely engaged. If the device(s) is/are not fully engaged the lift could fall unexpectedly, resulting in permanent damage to the device(s) or the lift.

## Recommended Lift Blocking Procedures (continued)

### **DANGER**

**If for any reason you are unable to lower the lift completely onto the maintenance device(s), stop immediately and consult the factory. Failure to properly use the factory approved maintenance device(s) could result in severe injury or death.**

5. Once the maintenance device(s) is/are properly and securely engaged, continue to press the down button, valve or switch for an additional 5-10 seconds to relieve all pressure in the operating system.

### **DANGER**

**Failure to relieve operating system pressure could result in the sudden and unexpected release of high-pressure fluids (or air) during maintenance and/or repair of the lift and result in severe injury or death.**

6. Follow OSHA electrical lock-out/tag-out procedures. Disconnect and tag all electrical and/or other power sources to prevent an unplanned or unexpected actuation of the lift.
7. Once inspection or work is complete, reverse the performance of the steps above to raise the lift off the maintenance device(s) and place the device(s) back into its/their designated storage position(s).

### **DANGER**

**HIGH VOLTAGE! – Disconnect and/or lock out the electrical supply to the power unit prior to any installation or maintenance being performed.**

## Maintenance Device Instructions

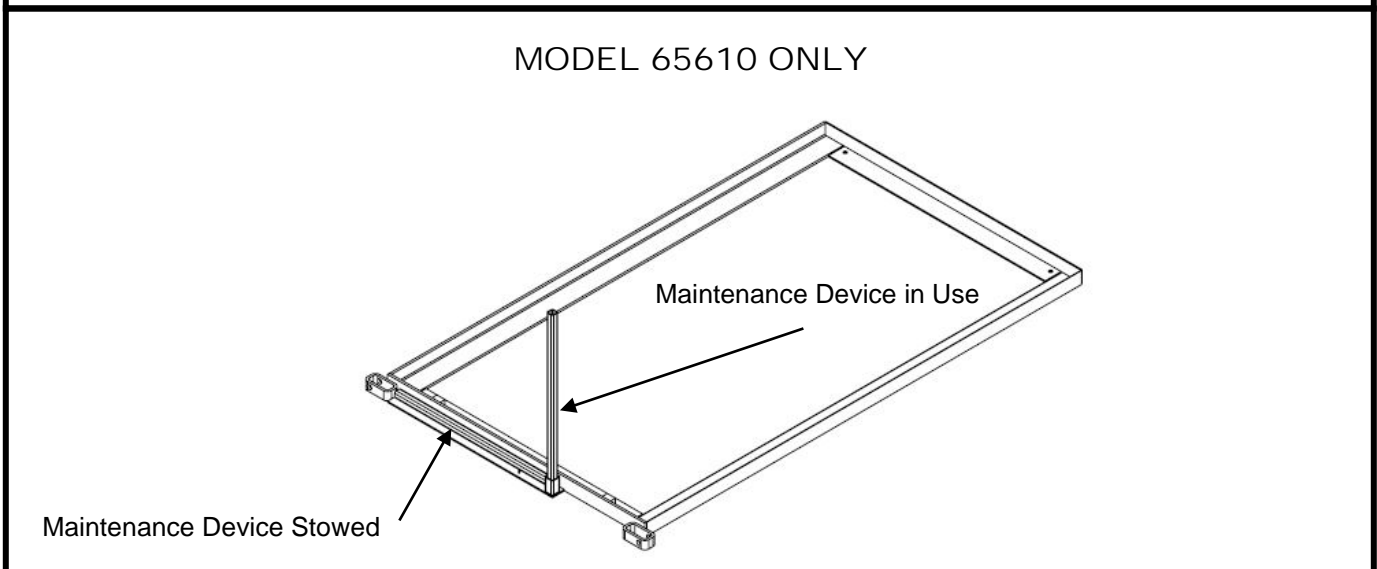
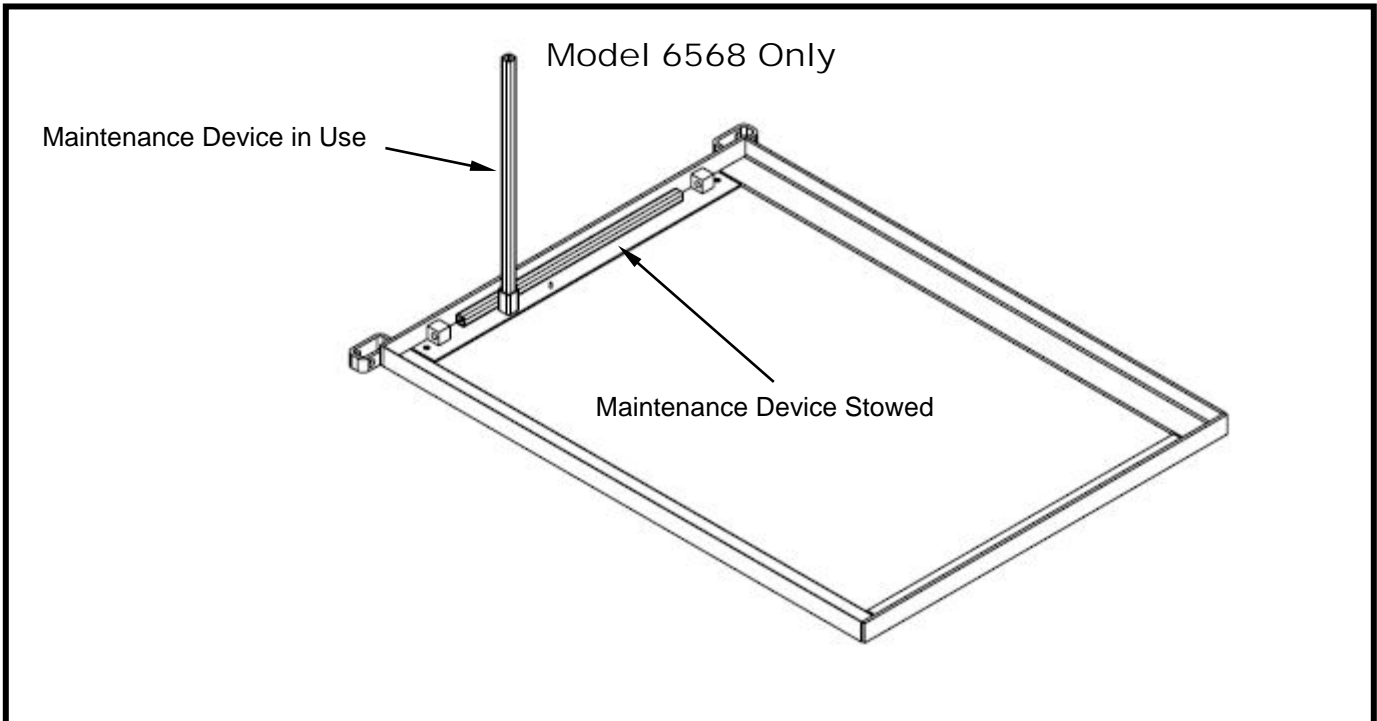

### WARNING

READ THE ENTIRE LIFT BLOCKING PROCEDURE AND ALL WARNINGS BEFORE ATTEMPTING TO USE THE MAINTENANCE DEVICE. FAILURE TO FOLLOW PROCEDURE MAY LEAD TO SERIOUS INJURY OR DEATH.

#### ALL MODELS

Never use the maintenance device when the platform has a load. Remove the load first, then brace for service or maintenance. Check that the maintenance device is well seated and remains so during heavy wrenching or maintenance operations.

#### MODEL 6568 & 65610

Raise equipment and position tube into the receiver cup. Lower lift onto tube. Hold the down button an additional 15 seconds to relieve all hydraulic pressure.

## Maintenance Device Instructions

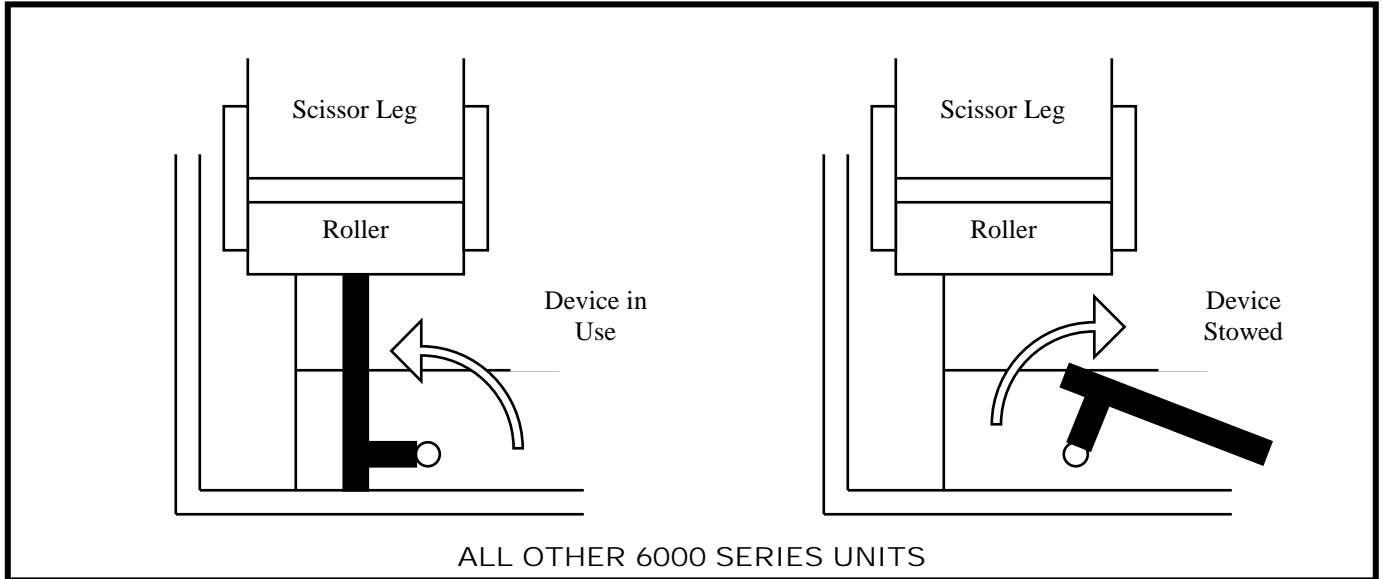

### WARNING

**READ THE ENTIRE LIFT BLOCKING PROCEDURE AND ALL WARNINGS BEFORE ATTEMPTING TO USE THE MAINTENANCE DEVICE. FAILURE TO FOLLOW PROCEDURE MAY LEAD TO SERIOUS INJURY OR DEATH.**

#### ALL MODELS

Never use the maintenance device when the platform has a load. Remove the load first, then brace for service or maintenance. Check that the maintenance device is well seated and remains so during heavy wrenching or maintenance operations.

#### OTHER 6000 SERIES MODELS

Raise equipment and rotate the Maintenance into usage position. Make certain the Device is fully rotated and resting on base frame then lower the lift onto the device. Hold the down button an additional 15 seconds to relieve all hydraulic pressure.

## SECTION 7. POWER UNIT ASSEMBLIES

This section contains drawings and photos of completed power units to aid service personnel in identifying each component. Please be careful to match the correct voltage and horsepower as well as model number, when you are trying to identify the power unit for your lift. Advance Lifts uses several different brand name motors and pumps, so the ones shown in the pictures may not be the same exact brands as on your unit. More information about individual components may be available in the hydraulic or electrical sections of this manual. Also note that these illustrations may show options that were not included on your particular unit and the components used may be changed at any time without notice.

### 6000 SERIES Power Unit\*

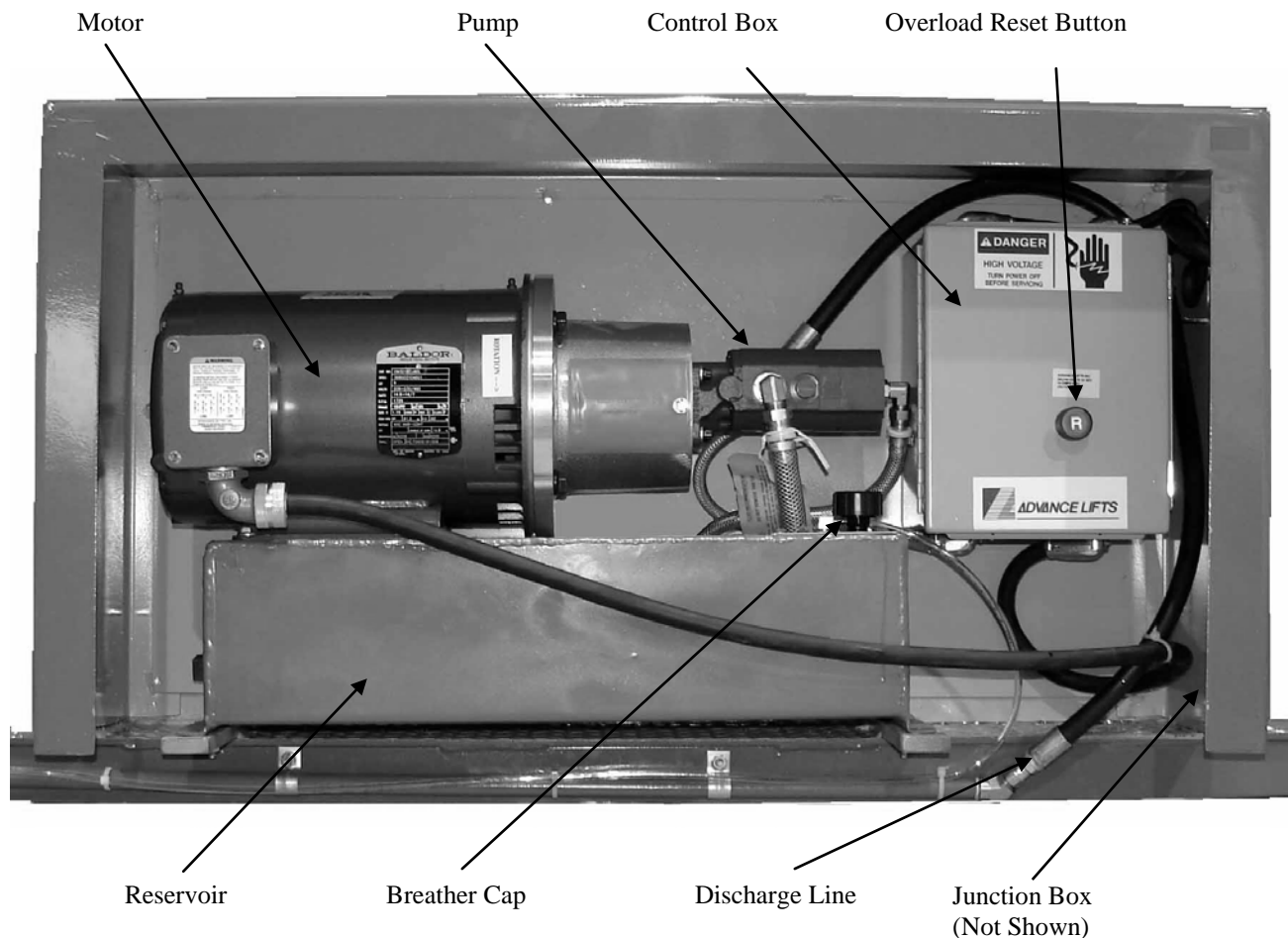

**See Page 8-4 for Hydraulic Diagram and Pages 9-3, 9-4 for Electrical Diagram**

\*FOR REFERENCE ONLY

## SECTION 8. HYDRAULIC DETAILS

### 1. General Hydraulic Information:

- A. All hydraulic cylinders will require the replacement of packing's and seals after a period of time, depending on usage and environmental conditions. It is normal maintenance just like changing oil in an automotive engine. However, maintenance personnel should recognize the difference between leakage and weepage:
- B. Weepage is the normal accumulation of fluid that passes the seals in the course of operations, as the hydraulic fluid properly performs its lubrication function on cylinder walls and piston rods. It may be occasionally observed squirting from cylinder breathers, but should stop squirting after several cycles of full stroke when the small accumulation is cleared.
- C. Leakage is the fluid that leaks past worn or cut packing's and seals. It too may be observed squirting but does not stop after several cycles and the lift will probably not hold position under load.
- D. See repacking under cylinder repair procedures.
- E. Always be careful when working around cylinders, not to nick the extended rod or dent the cylinder casing, as this may cause damage to cylinder seals or packing's.
- F. If you elect to repaint or retouch part of the lift, cover exposed rods with plastic or soluble grease that can be removed after painting to insure that no paint sticks to the rods and damages packing's or seals.

### 2. General precautions:

- A. Be sure that all pressure is relieved from the hydraulic system before disassembling any components. Continue to hold the down button for several seconds after fully lowering the unit on its maintenance device or the ground, before opening a line or component.
- B. Always be careful to avoid contamination entering the system. Be especially careful with the ends of hoses that may fall into oil dry or dirt. If you suspect contamination, flush the system and components.

### 3. Hydraulic fitting sealant and torque:

- A. Advance lifts may be equipped with either NPT fittings (tapered) or SAE fittings (with "O" ring seals, depending on age, know the difference!
- B. Be careful when tightening NPT fittings not to over tighten and crack them. Swivel fittings are especially vulnerable and should only be snug enough to stop leaking.
- C. If leakage persists after tightening the fittings fairly hard, inspect fittings for burrs on the mating edges or the possibility of a 37 degree SAE fitting being mixed with the standard 30 degree NPT fittings, or either one being mixed with SAE 45 degree fittings.
- D. When using Teflon tape on NPT fittings, be sure the tape is started 1-1/2 threads back from the leading edge and only use 2 wraps to be sure that tape does not break off and contaminate the system. You may substitute pipe sealant with Teflon paste from Pro Lock or Loctite, but again don't over apply. Never use sealant or tapes on swivel fittings or SAE o-ring fittings.
- E. Never reuse old Teflon tape. Once a connection has been opened, remove all old tape and apply fresh tape.

## Oil Recommendations & Seal Compatibility

### Fluids:

1. The current standard hydraulic fluid is an ISO 46, (group II base) hydraulic fluid. This is the fluid normally supplied by the factory and is suitable for a temperature range of – 10 to +100 degrees Fahrenheit. When replacing or adding fluid to an Advance Lift, use only ISO 46 hydraulic fluid that is manufactured with a group II base oil. ISO 46 hydraulic fluid can be identified by its purple color.
2. **Caution!** Do not use any fluid that has not been approved by the Advance Lifts engineering department. Brake fluids and other hydraulic fluids may attack the system's seals or hoses.
3. A biodegradable or fire resistant fluid is also available, however you must contact the factory for its name, because it is also necessary to change some seals and/or hoses for total system compatibility, depending upon the specific model lift that you have.

### Seals:

Generally, the seals in the unit are Buna-N-Nitrile and polyurethane. The hoses are composed of either PVC for suction lines or braided wire. Always call the factory about special fluids rather than make assumptions on your own.

### Options:

1. For extremely cold applications we recommend an oil immersion heater which simply fits in the drain coupling on most units, replacing the drain plug, these are available in appropriate sizes from the factory. NOTE: A separate 120V, 20 Amp circuit is required for all oil immersion heaters.
2. For extremely warm temperature ranges over +100 degrees Fahrenheit consult the factory.



## Pressure Chart for Hoses & Pipes

Hose	SAE	Working PSI	Bursting PSI
1/4"	100-R2A	5000	20000
3/8"	100-R2A	4000	16000
1/2"	100-R2A	3500	14000
3/4"	100-12	4000	16000

Seamless Pipe	Working PSI	Bursting PSI
1/2" Schedule 80	4100	21000
3/4" Schedule 80	3500	17600
1" Schedule 80	3500	15900

Caution: Never use any hose or piping that does not meet or exceed the ratings listed above.

### Line Size Calculations

Formula:  $P = \frac{V \times Q}{18,300 \times D \times D \times D}$

Where: P=PSI loss per foot  
 Q=GPM flow  
 V=SUS viscosity @  
 Operating temp.  
 D=Inside dia. Of pipe  
 in inches

### Standard Oil Capacities of Listed Equipment

- 2 – Cylinder units, 5 Gallons
- 4 – Cylinder units, 7 Gallons

HYDRAULIC PUMP/VALVE ASM

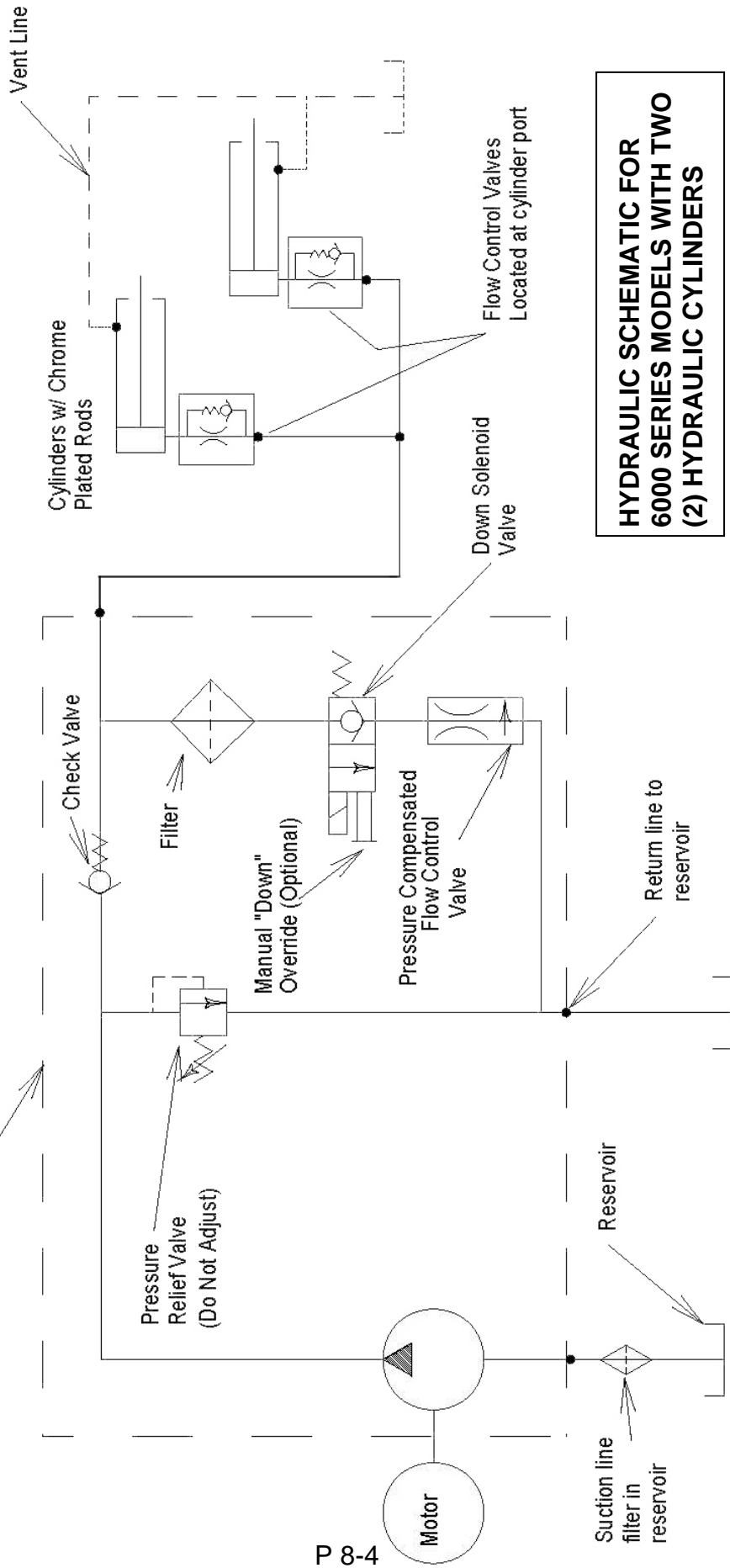

**HYDRAULIC SCHEMATIC FOR  
6000 SERIES MODELS WITH TWO  
(2) HYDRAULIC CYLINDERS**

Connecting hoses, supplied by Advance Lifts, Inc. ,connected by the installer. Hoses must be connected "A" TO "A" & "B" TO "B" as marked on valve manifold connection points.

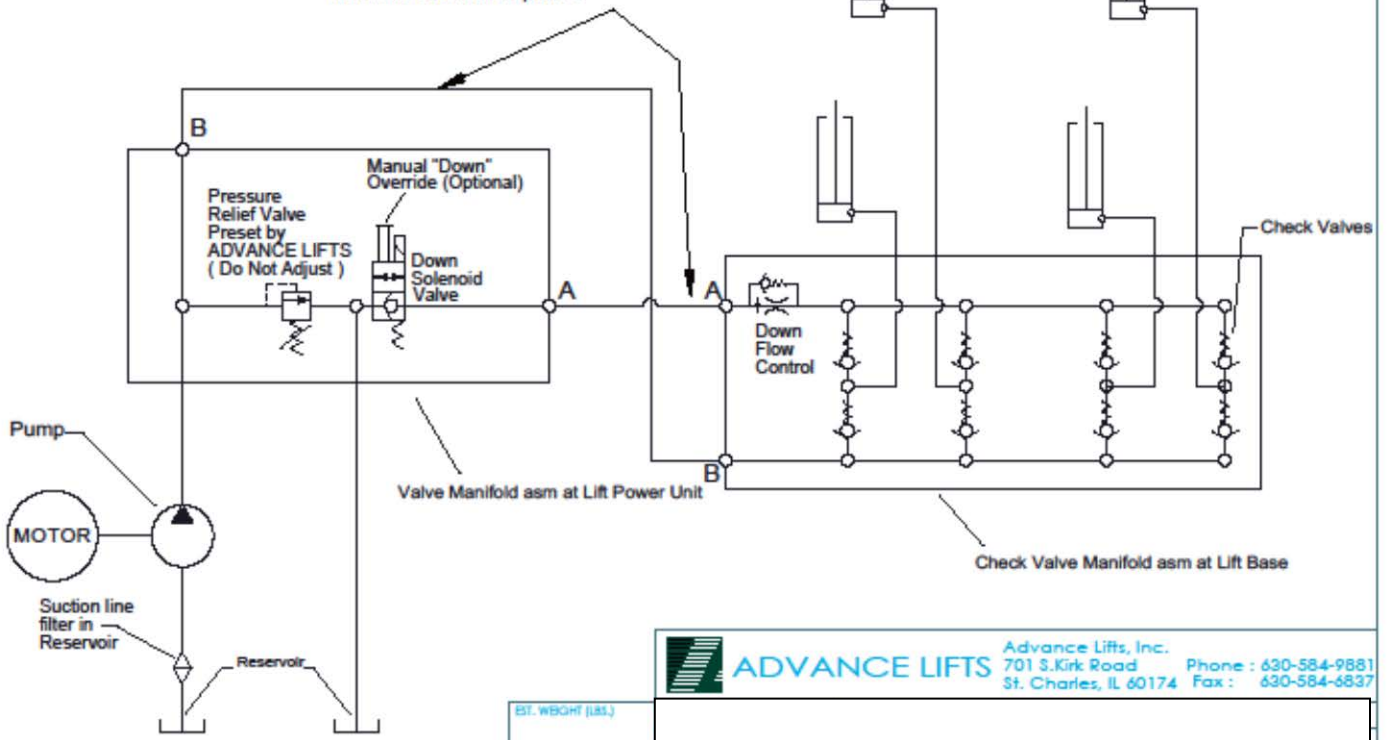

**ADVANCE LIFTS** Advance Lifts, Inc.  
 701 S.Kirk Road Phone : 630-584-9881  
 St. Charles, IL 60174 Fax : 630-584-6837

EST. WEIGHT (LBS.)	
DEFAULT TOLERANCES:	
JXX	±.005"
JXXK	±.001"
ANGULAR	±1°
UNLESS OTHERWISE SPECIFIED	

4 CYLINDER MODELS

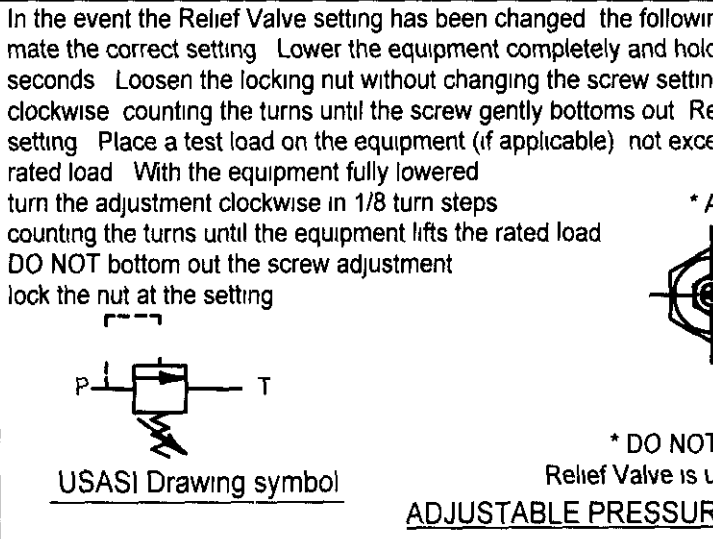
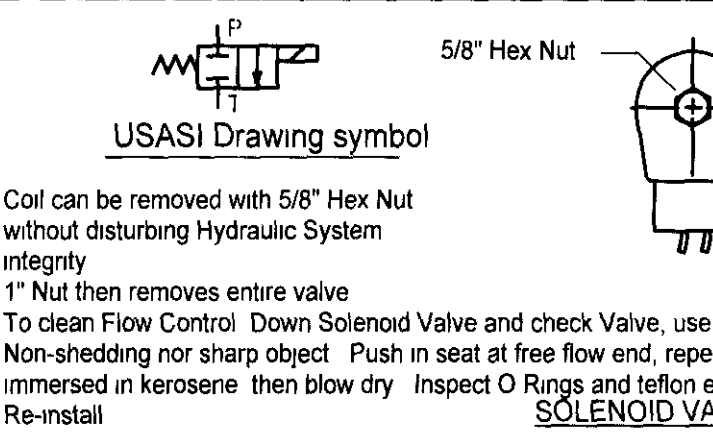
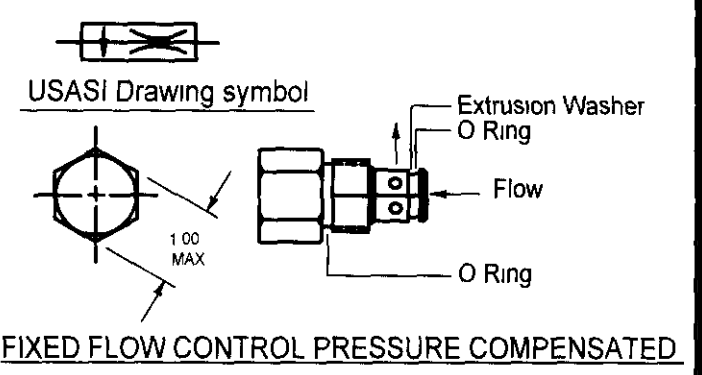
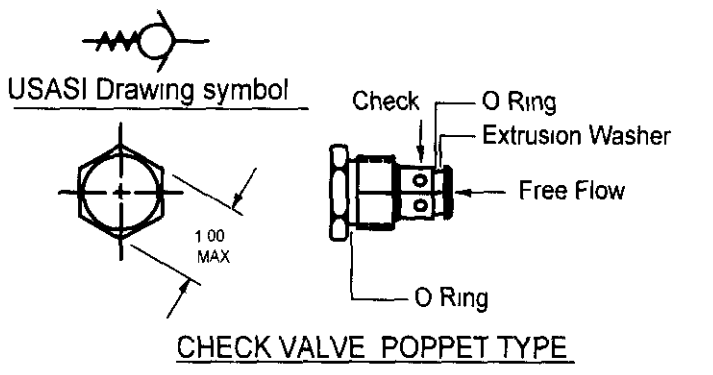

**NOTES** Velocity Fuse will close in controlled direction at nominal flow (plus 15% minus 0%) and remain closed at pressure above 50 PSI  
Rated 3000 PSI service material-steel  
If Velocity Fuse actuates support the equipment securely and correct the cause of the high flow rate ie cracked hose loose fitting etc Then put the hydraulic system under pressure again to re-set the Velocity Fuse Raise the equipment remove supports then operation is normal  
If Velocity Fuse is to be field installed Velocity Fuse is piped into Base of each Ram Use elbows and adapters as needed to hose hydraulic line 90 from Velocity Fuse laying the hydraulic hose so it will not be pinched when the equipment is lowered (by installer)

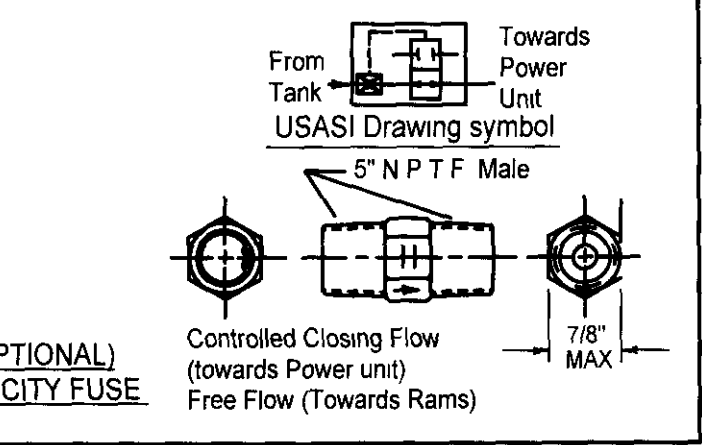

## Repair Procedures for Cylinders

### Tools & Supplies Required:

- (2) Small screwdrivers to remove retaining rings and rod wipers.
- A clean (5) gallon bucket to collect fluid from the cylinders.
- Wrenches to disconnect hydraulic fittings.
- Cylinder hone (Craftsman glaze breaker #9K4633 or equivalent).
- Emery cloth
- Clean lint free cloths and hose caps.
- Clean work surface (butcher paper on top of most surfaces works well), with a means of holding cylinder end fixed position for disassembly and assembly.
- “Lubriplate Grease” and hydraulic fluid matching the existing fluid in the system for topping off when finished.
- Maintenance device, supplied with each Advance unit.

### Cylinder Removal:

1. Raise the empty lift and settle it securely on its maintenance device.
2. Once settled securely, depress the down button an additional 20 seconds to relieve any pressure from the cylinders. Remove the power connection to the power unit and mark with a warning label or lock the connection out to prevent unintended reconnection.
3. Disconnect the hydraulic hoses from the cylinders, from below the deck.
4. Remove the retaining clips from the lower cylinder pin, then remove pin.
5. Thread a 3/8” I-bolt into the hole provided at the top of the cylinder and secure to a forklift or overhead crane. Once holding pressure is applied, remove the upper pin.
6. Cylinder is lifted up and out of the housing.
7. Place the hose connection end of the cylinder in a 5-gallon bucket and force the cylinder closed to drain the hydraulic fluid from the cylinder. Do not reuse the fluid unless you are sure it is contamination free by careful straining.
8. Note that if you are going to repack one cylinder on a lift, it is usually a good idea to do all cylinders at the same time. Packing’s generally wear at the same rate and if you only repack one cylinder, you may have to pull the lift out of service soon thereafter to do the others.
9. To install cylinder, reverse steps 6-3

### Cylinder Disassembly:

1. Secure the cylinder with a rod through the clevis or cross tube, do not use a vise, which will crush or otherwise damage the housing.
2. Using screwdrivers remove the spiral type retaining ring in front of the cylinder bearings.

### **Cylinder Disassembly: (Continued)**

3. Carefully remove any debris from the retaining grooves, and then pull out the entire rod, bearing, & piston assembly. Note that the groove in the cylinder housing has a sharp edge on the front side and a beveled back edge. The sharp edge is necessary for proper snap ring retention and will probably cut the packing when it is pulled out, but the beveled back edge will allow the new packing to slide in uncut.
4. Remove the hex nut or snap ring adjacent to the piston, then slide the piston and bearing off of the rod. If the hex nut is assembled with Loctite, a small amount of heat may help break the nut loose. Be sure that all components are placed on clean surfaces to avoid contamination.

### **Repacking and Inspection:**

1. Carefully inspect the entire housing with a flashlight, looking for any evidence of rust, scratches, or surface blemishes. Small blemishes may be removed with fine emery cloth and larger faults will require the use of the hone listed above. Be sure to thoroughly clean the housing when you are done to avoid contamination.
2. Do not become the victim of a false economy by using only part of a repacking kit. Since you have invested in disassembling the cylinder, use all new packing parts and seals of the reused old parts may fail in the near future causing a repeat of the whole exercise.
3. Remove the rod wiper on the bearing by using a screwdriver to bend the seal inward to collapse and remove it. Inspect the groove and remove any debris.
4. Lubricate and insert a new wiper with your fingers, sliding it into its groove. Depending upon temperature, the rod wiper may slide in much easier if it is warmed in hot water, then dried, lubricated, and inserted. The bearing may now be slid back onto the rod.
5. Begin repacking the piston by using a screwdriver to carefully remove the old backup rings and seal from the groove. Newer cylinders are also equipped with a wear ring that should be removed at this time. Be careful to leave the grooves nick free and clean.
6. Lubricate the new backup rings, seal and wear ring and gently stretch them into place. Note that the seal fits between the rings.
7. Inspect the static seal groove on the cylinder rod, then lubricate the groove and slide a new static seal in place. Slide the piston back into position noting that the flat side, not the chamfered side, should rest against the retaining ring or nut. Reinstall the retaining ring or nut using Loctite if the fastener is a plain nut.

# 6000 Series Cylinder Drawing

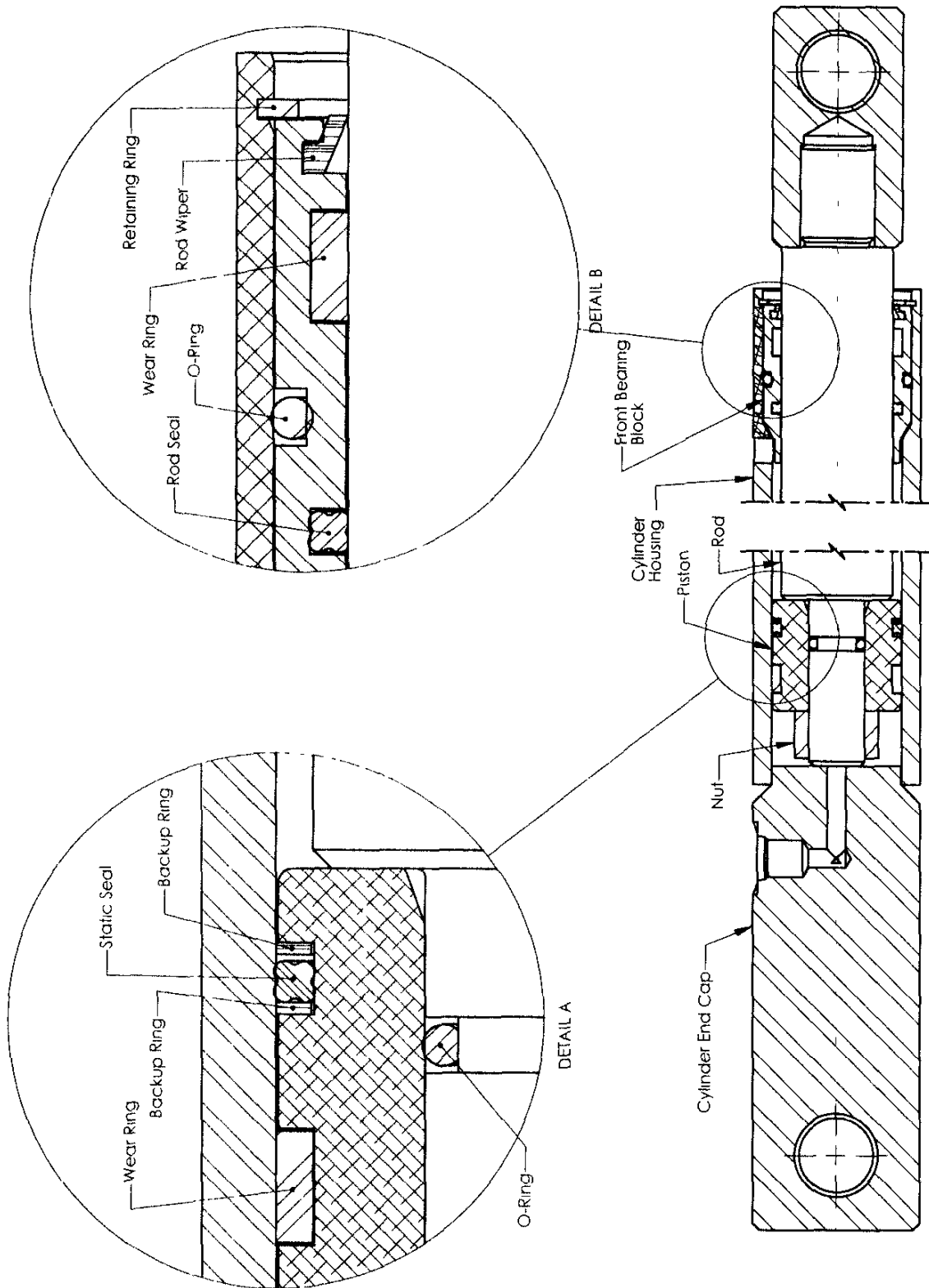

## Section 9. Electrical Information

The motor supplied as standard is 208/230/460V 3-phase motor, with connection diagrams on the outside of the motor for low voltage, 230V or high voltage, 460V. This motor connection is also rated for 208V. As any standard motor is rated for +/-10% of voltage variation, this motor will operate properly, within ratings, at 208, 220, 230, 240, 440, 460, and 480V, 3-phase supply. There are other motor configurations including single phase 115V & 230V. If you are unsure of the correct voltage or phase, contact the factory before applying line voltage.

If the standard motor is intended for 208V line usage, some caution is advised. If your motor is a 230V motor, and your 208V line voltage drops to 207 Volts (a drop of only ½%), the motor will be operating at -10% in a marginal region. Wiring runs and actual 208 voltages become very important. If your line voltage varies (due to loads elsewhere in the system, etc.) you may have an advantage by ordering as an option a specific 208V +/-10% motor.

To reverse the direction of rotation on a 3-phase motor, reverse any two of the three power leads to the motor. On single-phase motors, see wiring diagram on motor.

### **Field Changes in Voltage:**

Advance Lifts' standard electrical supplied is 230V, 3-phase unless otherwise specified. Any field change in supply voltage would entail the following changes.

#### **230V to 460V**

- A. Change transformer primary connections to 460V.
- B. Change overload protection to proper value as per currents in motor tables. Order new overload; adjust new overload to motor full load current setting. Insure the overload is set to "manual" reset, not "automatic" to insure the equipment cannot re-start automatically.
- C. Change motor connections for high 460V.
- D. Change plug and receptacle for power, if required.

#### **460V to 230V**

- A. Change transformer primary connections to 230V.
- B. Change overload protection to proper value as per currents in motor tables. Order new overload; adjust new overload to motor full load current setting. Insure the overload is set to "manual" reset, not "automatic" to insure the equipment cannot re-start automatically.
- C. Change motor connections for low 230V.
- D. Change plug and receptacle for power, if required.

**IMPORTANT: When changing voltages, insure motor rotation is correct.**



## Motor Controllers (Typical)

### Specifications:

Motor Starter with adjustable thermal overload.

50VA transformer with 24 VAC secondary fused at 4 amps (Standard)

100VA transformer with 115 VAC secondary fused at 1.6 amps (Optional)

Reset is manual or automatic (manual is standard, automatic is not to be used)

Enclosure is NEMA 12 JIC supplied with (4) conduit openings (motor, down solenoid, power and push button station)

Completely wired with terminal strips for final secondary voltage control connections  
All components UL, CSA

Overall dimensions: (approximate)

Metal Enclosures: 9"w x 12"h x 8"d

**Typical motor controller** – appearance may vary.

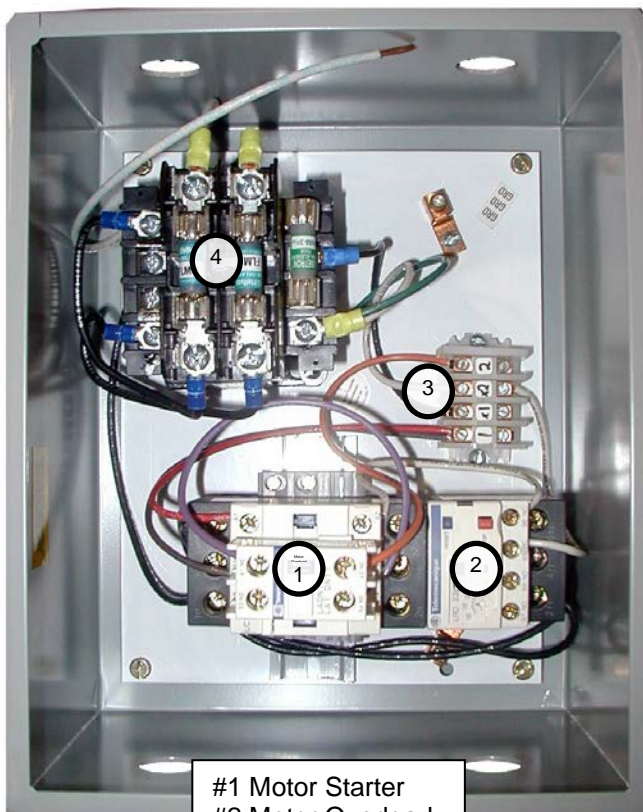

#1 Motor Starter  
#2 Motor Overload  
#3 Terminal Strip  
#4 Transformer



# ADVANCE LIFTS WIRING DIAGRAM FOR 230 VOLT SINGLE PHASE 5 HP

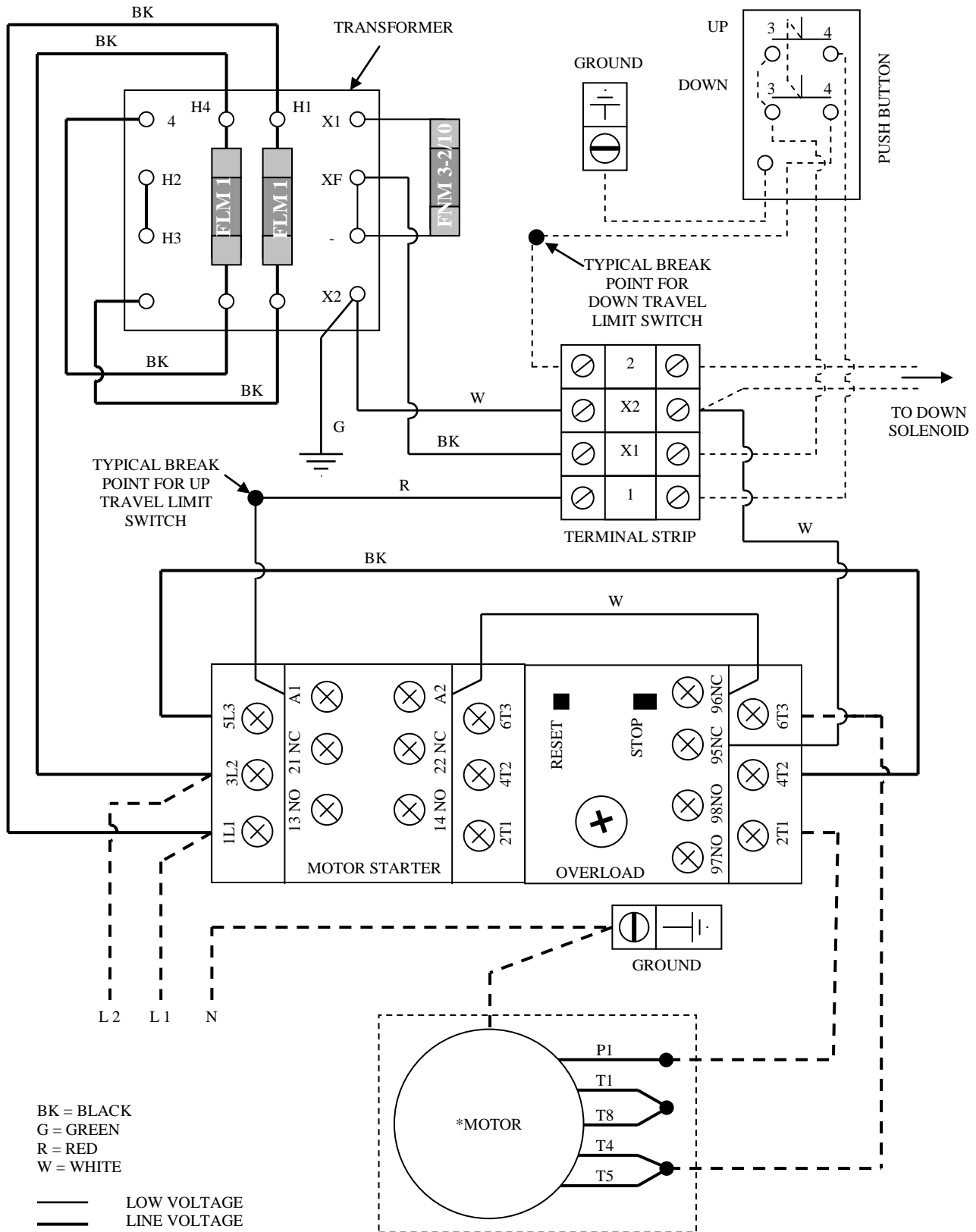

BK = BLACK  
G = GREEN  
R = RED  
W = WHITE

— LOW VOLTAGE  
— LINE VOLTAGE

--- LOW VOLTAGE (FIELD WIRED)  
--- LINE VOLTAGE (FIELD WIRED)

INTERNAL MOTOR CONNECTIONS  
\* TO CHANGE ROTATION SWAP T5 & T8

12/12/07

# ADVANCE LIFTS WIRING DIAGRAM

## 230 VOLT THREE PHASE 5 & 7.5HP

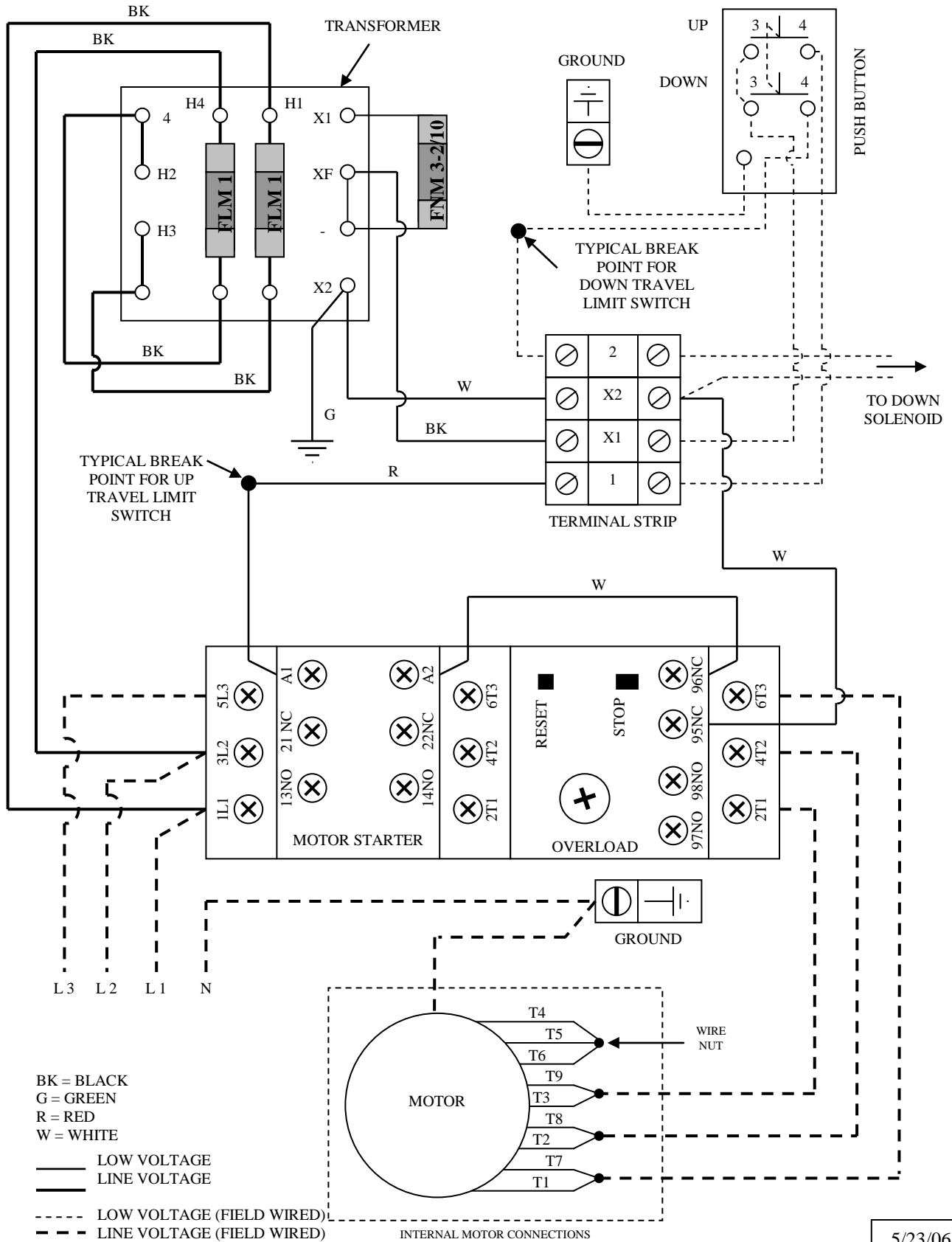

5/23/06

# ADVANCE LIFTS WIRING DIAGRAM

## 460 VOLT THREE PHASE 5 & 7.5HP

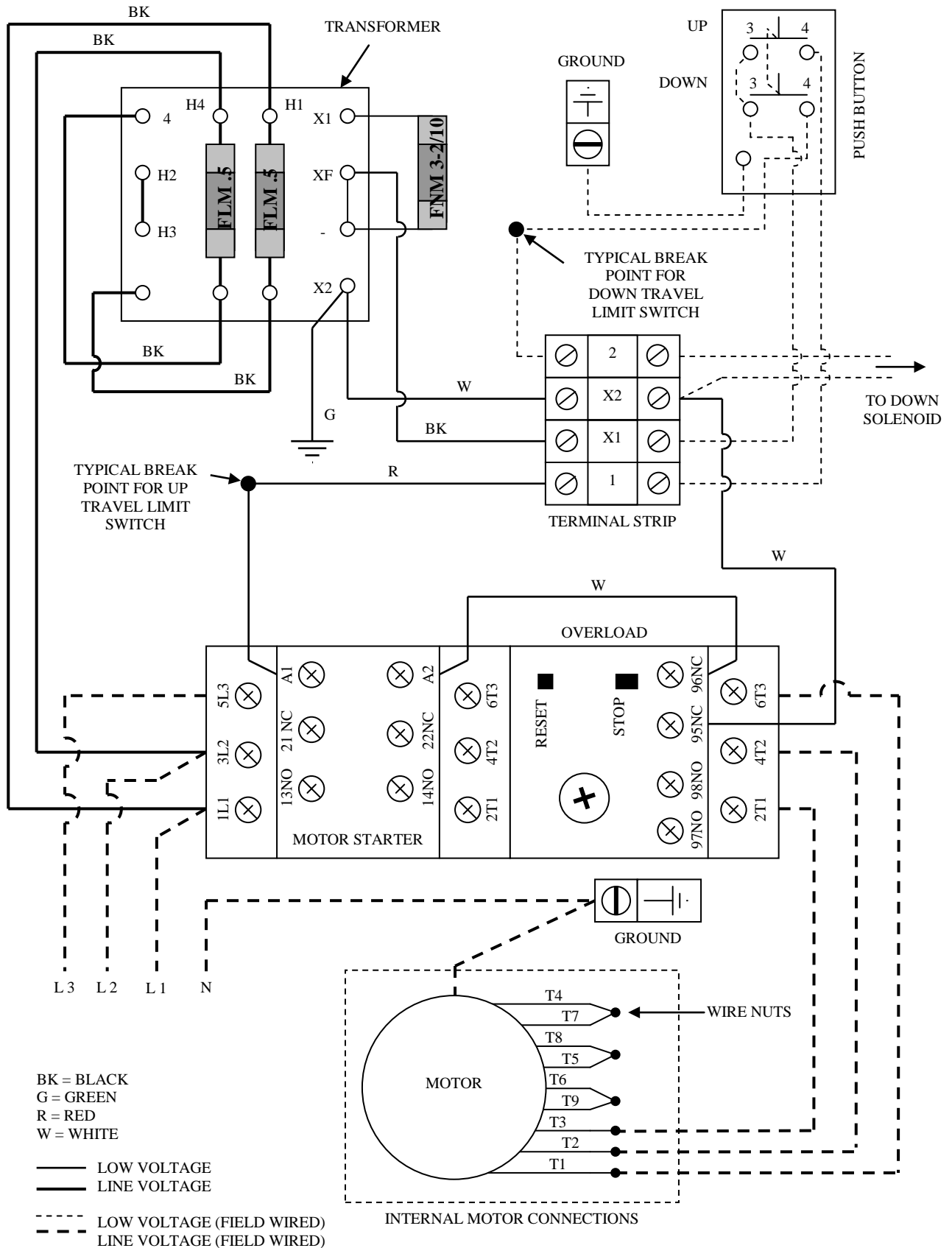

## TYPICAL MOTOR INFORMATION

TWO CYLINDER UNITS, 5 HP MOTORS  
FOUR CYLINDER UNITS, 7.5 HP MOTORS

230 VOLT 3 PHASE					460 VOLT 3 PHASE				
HORSEPOWER	APPROX FULL LOAD AMPS	MIN COPPER WIRE SIZE (75C) THW,THHN,THWN,XHHW	CIRCUIT BREAKER AMPS	DUAL ELEMENT TIME DELAY FUSE AMPS	HORSEPOWER	APPROX FULL LOAD AMPS	MIN COPPER WIRE SIZE (75C) THW,THHN,THWN,XHHW	CIRCUIT BREAKER AMPS	DUAL ELEMENT TIME DELAY FUSE AMPS
1	3.6	14	15	5.6	1	1.8	14	15	2.8
1-1/2	5.2	14	15	8	1-1/2	2.6	14	15	4
2	6.8	14	15	10	2	3.4	14	15	5.6
3	9.6	14	20	15	3	4.8	14	15	8
5	15.2	12	30	25	5	7.6	14	15	12
7-1/2	22	10	45	30	7-1/2	11	14	20	17.5
10	28	8	60	40	10	14	12	25	20

115 VOLT 1 PHASE					230 VOLT 1 PHASE				
HORSEPOWER	APPROX FULL LOAD AMPS	MIN COPPER WIRE SIZE (75C) THW,THHN,THWN,XHHW	CIRCUIT BREAKER AMPS	DUAL ELEMENT TIME DELAY FUSE AMPS	HORSEPOWER	APPROX FULL LOAD AMPS	MIN COPPER WIRE SIZE (75C) THW,THHN,THWN,XHHW	CIRCUIT BREAKER AMPS	DUAL ELEMENT TIME DELAY FUSE AMPS
1/2	9.8	14	20	15	1/2	4.9	14	15	8
3/4	13.8	12	25	20	3/4	6.9	14	15	10
1	16	12	30	25	1	8	14	15	12
1-1/2	20	10	40	30	1-1/2	10	14	20	15
2	24	10	50	30	2	12	14	25	17.5
3	34	8	70	50	3	17	10	35	25
5	56	-	-	-	5	28	8	60	40

**NOTE:** These tables are intended as a guideline, not to supersede national or local electrical codes.

# Branch Circuit Wire Sizes For 230V & 460V, 3 Phase, 60HZ.\*

(Calculated for 2% maximum allowable line voltage drop with copper conductors Table is a guideline, not intended to supersede the National Electrical or local codes )

Directions Locate Current on vertical axis, locate wire length on horizontal axis Use wire size above point of intersection

\*Note See table listing minimum wire sizes and fusing on motor data page

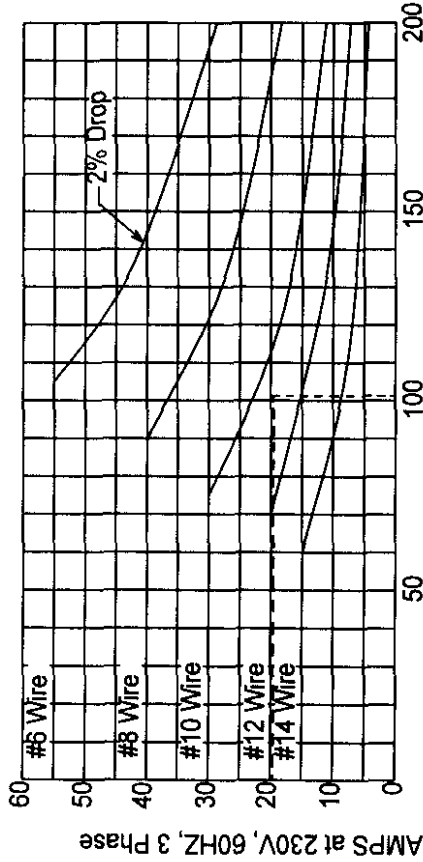

Example 5HP, 230V, 3 phase, 19 6A motor, length of wire run is 102 FT Wire size above point of intersection is #10 (#12 wire would have more than 2% drop )

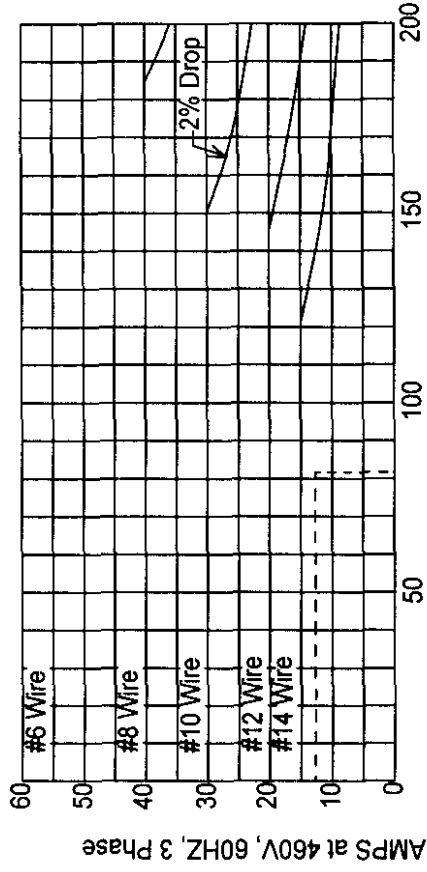

Example 7.5HP, 460V, 3 phase, 12 6A motor, length of wire run is 82 FT Wire size above point of intersection is #14

Long wiring runs with undersized wire will cause voltage drops Voltage measurements should therefore be made at the motor terminals, so that the true voltage supplied to the motor is determined Measure the voltage when the motor is fully loaded (load on lifting equipment and lift leaving the fully lowered position) Measurements with the motor idling (no load) is at low current, and voltage drops will not be apparent under those circumstances Consult the table in this manual for guidelines on wire run sizes Note importance of 208V wire runs as noted in Motor Data

## Branch Circuit Wire Sizes For 230V & 115V, 1 PHASE, 60HZ

(Calculated for 2% maximum allowable line voltage drop with copper conductors. Table is a guideline, not intended to supersede the National Electrical or local codes.)

Directions: Locate Current on vertical axis, locate wire length on horizontal axis. Use wire size above point of intersection.

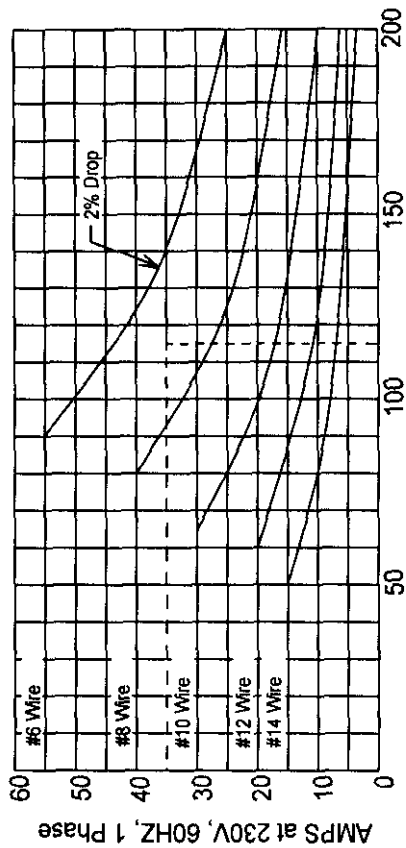

Example 5HP, 230V, 1 phase, 35A motor, length of wire run is 115FT. Wire size above point of intersection is #8.

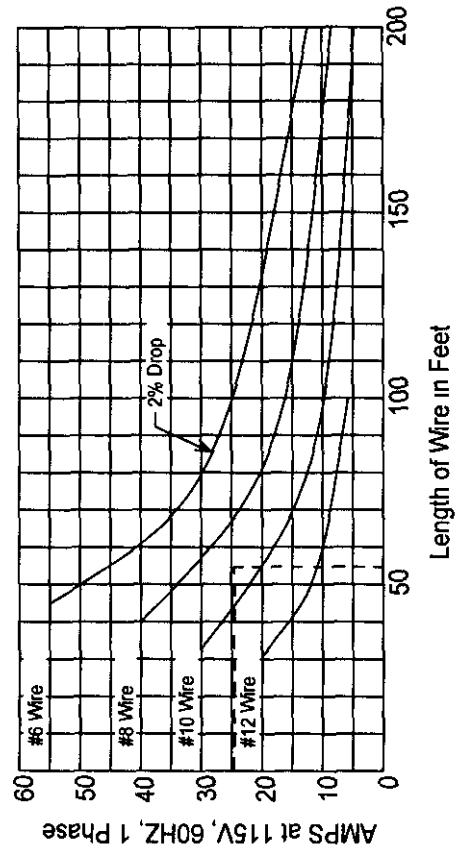

Example 1.5HP, 115V, 1 phase, 24A motor, length of wire run is 55FT. Wire size above point of intersection is #8.

## CONTROL CIRCUIT WIRE SIZE FOR 24V, 1 PHASE, 60HZ

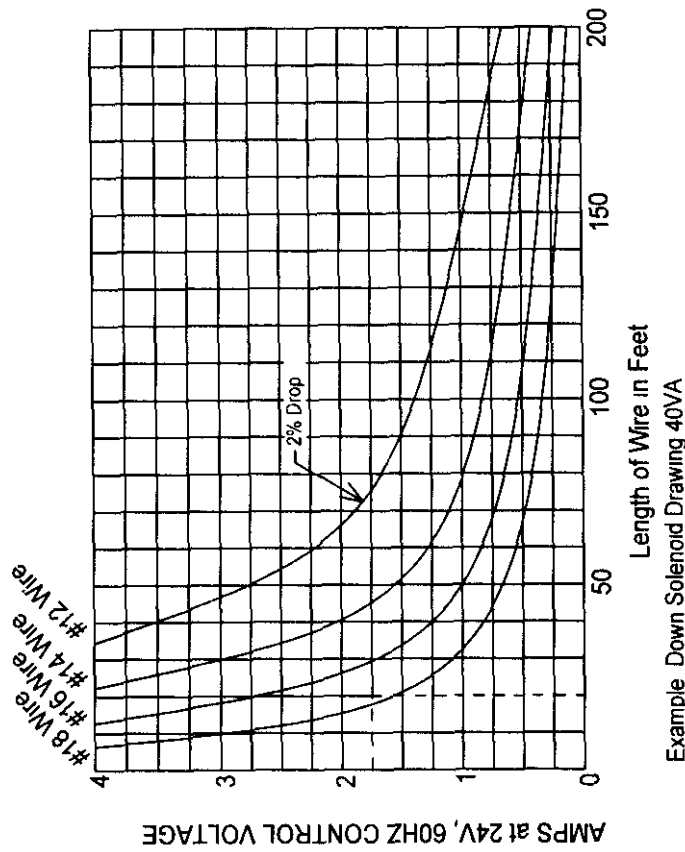

Example Down Solenoid Drawing 40VA

$$I = \frac{W}{E} = \frac{40VA}{24A} = 1.7A$$

Length of coil cord is 20FT. Wire size above point of intersection is #16.

Advance Lifts uses #16-4 wire size when 20FT coil cord is ordered for push button station control.

\*Graph calculated for 4 wire copper cord, types S, SO, SJ, SJO

SECTION 10. IDENTIFICATION AND LABEL PLACEMENT

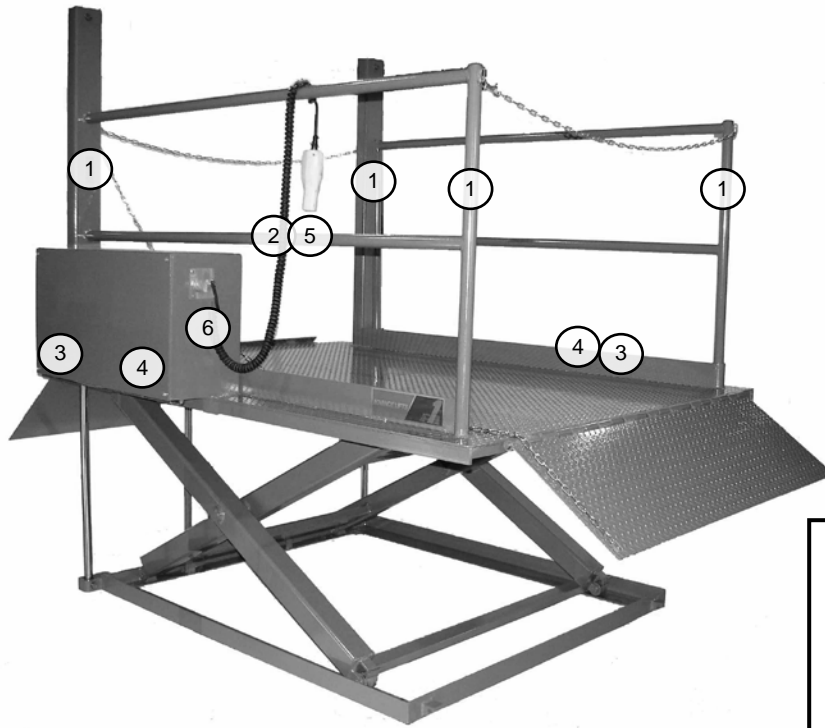

**WARNING**  
**USE**  
**HANDRAILS**  
**AND**  
**CHAINS**  
**WHILE**  
**OPERATING**  
**LIFT**

Label #1 located on all guardrail uprights

**CAPACITY LABELS,** placed on two long sides of the platform.



Label #3 located on power unit enclosure and opposite side kick plate



Label #2 center top of mid-rail, both sides, next to #5



Label #4 located on power unit enclosure and opposite side kick plate



Label #5 located on top center of all mid-rails

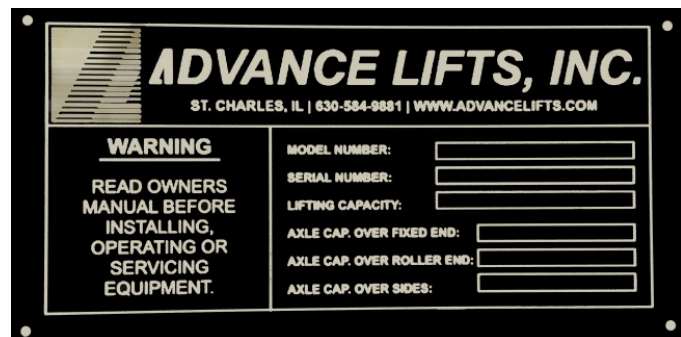

#6 Serial Tag located on power unit enclosure



## SECTION 11. TROUBLESHOOTING

### **A. Equipment does not rise; pump is running: (see also Section M)**

1. The motor rotation may be reversed. See the installation procedure on how to jog the motor to check for proper rotation. If the lift has been installed for some time and the motor is 3-phase, it is possible that the plant wiring “upstream” has been changed during plant maintenance or alteration, and the motor is now running reversed. A hydraulic pump can only run reversed for a short time (possibly 10 to 20 seconds) without causing permanent pump damage.
2. Motor may be single phasing. Check wiring and overloads to be certain that each three-phase line is present at the motor.
3. Voltage at motor terminals may be too low to run the pump at existing load. Check voltage directly at motor terminals while pump is running under load. (Reading source voltage with the pump idling will not give accurate results). Inadequate or incorrect wiring can starve the motor of voltage and current and will show up at the motor terminals when the motor is drawing the higher current that is required while motor is loaded.
4. Check for a hydraulic hose leak or pinching, and correct as necessary.
5. Check under the pump coupling to insure the key way has not slipped off the pump shaft.
6. Check for oil shortage in the reservoir and correct by filling the reservoir. Refer to “Fluid Recommendations” in this manual for the correct fluid for your ambient temperature.
7. The suction filter in the reservoir or the pressure line filters in the pipe outlet of the power unit or the breather cap on the reservoir may be clogged. Clean as required.
8. Check if the load is exceeding equipment ratings causing the relief valve to bypass the fluid back to the reservoir. Never change the relief valve setting, these are 100% tested, adjusted, and locked at the factory. Any change in the relief valve setting could cause your equipment either not to lift its capacity, or cause dangerous forces in the equipment, and void your warranty.
9. Check that the suction line fittings are not loose, causing the pump to pull in air instead of fluid. Check for a hairline crack on the suction port of the pump. The clear suction line should stay full of oil at all times, clear, and no air. Check that the natural curve of the suction hose in the reservoir doesn't cause the filter to rise out of the fluid. Re-install the suction line without rotating it and the tension of the hose will free the suction hose to lie against the reservoir wall and the filter to lay flat near the reservoir bottom. If you have the short round “pancake” type of filter with the filter screen on the bottom of the filter, insure that it does not rest against the bottom of the reservoir, as this will restrict the flow to the pump.

## SECTION 11. TROUBLESHOOTING (Continued)

10. The down solenoid may be energized due to incorrect wiring, or mechanically stuck open, bypassing fluid.
  - A. Check the wiring. Hold a non-magnetized screwdriver to the top of the down solenoid coil and press the up button. If you can feel magnetism, the wiring is faulty.
  - B. Lightly tap the down solenoid to seat it properly. Do not bang it hard, as internal stem parts may be permanently damaged. The solenoid coil can be removed, and the down valve removed for cleaning as explained in the hydraulic "Component Information" section.
  - C. Disconnect the pressure line from the valve manifold to the equipment. Place a pressure gauge at the valve output, using high-pressure reducers. Press the up button in a short jog and read the pressure. Press the down button to relieve the pressure. If the system will not put out the pressure indicated on the hydraulic diagram, the trouble is either the valves or pump. If a load is not available, then the maximum hydraulic system pressure can be checked on a gauge by raising the unit to its full height momentarily against its physical stops. Proceed to step 11 to determine which place the trouble exists.
11. The hydraulic pump may be inoperative. Disconnect a hydraulic line at the power unit, use a large bucket (5-gallon) and run the pump a short time. If no flow appears either the pump or pump motor coupling inside motor mounting flange is defective, or pump rotation is reversed. Connect a pressure gauge to the outlet of the pump, through a high-pressure tee and bleeder valve with hose to a bucket. Slowly turn the bleeder valve and see if it produces specified pressure. Do not close the valve all the way as the pressure buildup of a good pump could cause the pump to explode. If the pump does not put out the required pressure, then the problem is in other areas, such as a down solenoid valve leaking fluid back to the reservoir, allowing pressure not to be built up in the system. If the pump will not put out the required pressure, replace the pump.
12. Repeated continuous type operation of the equipment may cause thinning of oil due to heat buildup. Feel the side of the reservoir to check the temperature of the oil. The equipment is intended for dock type operation, not elevator type operation that would make the equipment cost several times as much. The thin oil can cause the equipment not to rise, and in time, ruin the hydraulic pump. This type of operation could void the warranty considerations.

### **B. Equipment raises too slowly:**

1. Small amounts of foreign material could stick in the down solenoid, bypassing some of the fluid. Lower equipment and clean the down solenoid valve.
2. Foreign material clogging the suction filter, breather cap, pressure line filter, or a hose that is pinched. See A-4, 5, 6, 7 and 9.
3. Low motor voltage. See A-3.
4. Load exceeding equipment ratings. See A-8.
5. Oil may be too thick (ambient temperature) for proper operation. Refer to "Fluid Recommendations".

## SECTION 11. TROUBLESHOOTING (Continued)

6. Equipment in which the cylinders are field installed may have incorrect alignment of cylinders, causing binding. Measure and ascertain that the cylinders are in the correct alignment with the equipment and with each other. Binding cylinders will often cause a “shuddering” vibration when the equipment is operating.
7. Oil may be too thin for ambient temperatures. See A-12

### **C. Motor labors or heats excessively:**

1. Voltage may be too low. See A-3.
2. Wiring may be incorrect. Check that one leg of the motor lines is not open or grounded.
3. Pump may be overheating from oil starvation that develops high internal heat, heating both the motor and the pump, eventually causing pump failure. See A-1 through A-9.
4. Oil may be too thick for ambient temperature. See “Fluid Recommendations”. Binding cylinders. See B-6.
5. Pump may be overheating due to insufficient lubrication caused by oil being too thin. See A-12.

### **D. Operation is “spongy”:**

1. Bleed the cylinders to release trapped air by lowering the equipment to the fully down position and hold the down button depressed for an additional 20 seconds. Raise lift and repeat this procedure several times. Check that the oil completely fills the clear suction hose at all times. If the level falls back to the reservoir oil level, check suction lines and fittings for an air leak.
2. Check for oil starvation. See A, 1-9.
3. Do not confuse “spongy” operation with small surges caused by foreign material on equipment wheel roller plates.

### **E. Equipment lowers too slowly:**

1. Pressure filter in pipe outlet of power unit may require cleaning. See “Component Information” for proper procedure.
2. Check for pinched hose, tubing, or obstruction in piping lines.
3. Check “Fluid Recommendations” for your ambient temperature type. Oil may be too thick. See also H-6.
4. Foreign material in flow control valve. With equipment fully lowered, remove and flush out any foreign material. Do not change flow control setting, as equipment could be damaged by high speeds. See “Component Information” for proper way to remove, clean, and install the flow control valve.
5. Equipment having two down solenoid valves and/or flow control valves may have one valve inoperative.
6. Binding cylinders. See B-6.

## SECTION 11. TROUBLESHOOTING (Continued)

### F. Equipment lowers too fast:

**CAUTION! This can develop into a dangerous condition, the equipment reaching destructive speed. Find and correct this condition before allowing use of this equipment.**

1. Check for leaking hoses, particularly cracked fittings or other damage caused by equipment motion near the equipment and power unit, over-tightening of fittings until they develop hairline cracks. Check underground conduits for evidence of fluid leaks.
2. Inspect the check valve. The combination of the flow rates of the down flow control valve and a check valve stuck open due to foreign material, could increase the lowering speed. See G-2.
3. If the equipment lowers initially at a normal rate, then speeds up as the equipment lowers, check the flow control valve(s). Foreign material could stick, not allowing the pressure compensated function of the control to operate normally. See "Component Information" for the method of removal and replacement.
4. Oil may be too thin. See A-12.

### G. Lift raises then lowers back down:

1. Down valves may be incorrectly wired or stuck open due to dirt in the system. See A-10, a. & b.
2. Check valve may be stuck open due to dirt in the system. See "Component Information" for removal, cleaning and installation. If pump and motor turns backward while the lift is lowering back down, the check valve is certainly inoperative.
3. Cylinder packing may be leaking. Check for oil leakage, see "General Hydraulic Information" and section on "Cylinder Repair Procedures".
4. Check for leaking hoses, fittings, or evidence of oil in underground conduit runs.

### H. Equipment has raised but will not lower, or lowers partly:

1. Check both main and transformer secondary fuses.
2. Incorrect down solenoid wiring.
3. Stuck down solenoid valve. See A-10b, however do not remove the down solenoid body, as the equipment will come down with nothing to hold it in place.
4. Faulty down solenoid coil. Coil can be removed safely for replacement. As in step 3, do not remove valve body.
5. The maintenance device or other object blocking down travel. Do not pry out any object blocking down travel, because the hydraulic pressure has already been removed when the down button was pressed, and the equipment will fall at a dangerous speed. Raise the equipment slightly using the up button, remove object, then press the down button.

## SECTION 11. TROUBLESHOOTING (Continued)

6. Improper oil for ambient temperatures. Oil may be too thick, causing improper operation of velocity fuses (if used). See "Component Information" on velocity fuses. Warm the cylinders by wrapping heat tape (of the type used for water pipes) around the cylinder. Later, after operation is normal, change to proper oil as per "Fluid Recommendations".
7. Binding Cylinders. See B-6

### **I. Equipment raises slightly, then equipment stops and motor stalls:**

Check the suction line filter. Filter may be clogged, allowing slight movement until grime seals off filter. Check the suction filter for buildup of "varnish". If necessary, remove the suction filter, hold the suction hose down into the oil, and try normal up operation of equipment. If operation returns to normal either clean or replace the suction line filter. See the "Component Information" section for procedure and proper placement of the suction hose.

### **J. Oil leaking or spraying out of the reservoir:**

1. Clogged air breather allowing reservoir to build up positive pressure, then spraying oil. Try unit operation with air breather removed and clean or replace the air breather if this corrects the condition.

### **K. Equipment will not raise, motor will not run:**

1. Control fuse has blown.
2. Motor starter overload has tripped. Depress reset button on controller.
3. Line fuse blown, single phasing motor or motor starter overload tripping. See #2 above.
4. Initial installation: Line voltage 230V and transformer wired for 460V. This will give 12V-control voltage instead of 24V, and motor starter will not operate. Check to make sure motor was not wired for 460V before trying operation. The same situation applies to 115V control voltage. Use a good AC voltmeter to check for proper control voltage.
5. Check transformer for loose screw terminals at the various connection points including jumpers and under the fuse clips.
6. Check push button station for proper operation and its wiring to the controller.

### **L. Down solenoid or Magnetic Starter Coil burns out routinely:**

1. Transformer may be wired wrong. As an example, a 460V line with the transformer and primary wired for 230V will give the control voltage of 48V instead of 24V. (Same doubling voltage applies to 115V control transformers.) This will burnout coils ranging from immediately to several month intervals, depending on the stamina of the coil. Correct the condition. P 10-5
2. The transformer may be defective. Check control voltage with a good AC voltmeter.

## SECTION 11. TROUBLESHOOTING (Continued)

3. Although very rare, high voltage spikes may be coming in on the power lines at random, burning out coils. This cannot be detected with a power company recorder, A "Varistor" can be purchased and easily installed on control systems to protect the coils. More severe cases on both 115V or 24V control systems may need a special "High Insulation Transformer" in place of the standard control transformer.

### **M. Equipment does not lift rated load, or raises load about 1" then stops:**

1. Check troubleshooting section (A), 2 through 11. Check if platform roller wheels roll freely with no binding as lift raises and lowers.
2. Lift may be overloaded. If a lift is listed as capable of fork truck loading, bear in mind that most "sit-down" rider fork trucks weigh at least 5,000 to 7,500 pound empty.
3. Platform may be shifted or damaged from transit or unintentional abuse.
  - A. Check if the inside edge of the bevel toe guard is rubbing against the base frame in the fully lowered position. Look for scratch marks on the base frame. Bend back bevel toe guards as required and see "b" below.
  - B. Check if the platform roller wheels are running straight on their platform members as the lift raises and lowers and legs or wheels are not rubbing on nearby platform members. Consult Advance Lifts on how to straighten out a platform.
  - C. Check that the platform roller wheels are actually rolling as unit rises.
4. There may actually be no problem. Many shipping tickets contain estimated weights much lower than the actual weight. The lift may be seeing a load based on shipping tickets, well above lift capacity. In this case the lift would not generally raise the 1" and stop, generally it will not lift at all from the full lowered position.

### **N. Breather lines do not stay connected.**

1. Be certain that the lines are not pinched.
2. Check that there is no debris in the lines.
3. Once a line has been removed from the fitting, the hose must be cut back before reinstallation.
4. If lines are completely filled with oil, drain oil out and test cylinders for seal failures.

## SECTION 12. ADVANCE LIFTS INC. PARTS AND LABOR WARRANTY

For a period of two years from date of shipment from the Company's plant, the Company agrees to replace or repair, free of charge, any defective parts, material or workmanship on new equipment. This shall include electrical and hydraulic components.

For a period of ten years from date of shipment from Company's plant, the Company agrees to replace or repair any defective structure.

Company authorization must be obtained prior to the commencement of any work. The Company reserves the right of choice between effecting repairs in the field or paying all freight charges and effecting the repairs at the Company's plant. The Company further reserves the right of final determination in all warranty considerations. Evidence of overloading, abuse, or field modification of units without Company approval shall void this warranty. No contingent liabilities or freight damage will be accepted.

Damage incurred in transport is the responsibility of the carrier and is not covered by this warranty. Any damage detected upon receipt of equipment should be immediately reported to the carrier. If you need assistance filing your claim, please contact Advance Lifts.

## 6000 SERIES PARTS LIST

GENERAL DESCRIPTION	PART #
<b>MECHANICAL: (COMMON TO ALL UNITS)</b>	
ROLLER WHEEL ASSEMBLY	A-0074
ROLLER WHEEL PIN	A-0075
WHEEL PIN SNAP RING	001-877
MAIN AXLE PIN	A-0073
MAIN AXLE PIN SNAP RING	001-063
<b>COMPLETE CYLINDER:</b>	
1568 CYLINDER ASSEMBLY	D-15751
<b>CYLINDER PARTS:</b>	
1568 CYLINDER PACKING KIT	036-968
UPPER/LOWER CYLINDER PIN	A-0548
CYLINDER PIN SNAP RING	001-876
<b>MOTOR: SELECT BY VOLTAGE AND PHASE</b>	
115/208/230V 1PH	000-319
230/460V 3PH 5HP BALDOR MOTOR	003-373
<b>PUMP: SELECT BY VOLTAGE AND PHASE</b>	
115/208/230V 1PH HALDEX HYDRAULIC PUMP #1003570	031-637
230/460V 3PH HALDEX HYDRAULIC PUMP	027-276
<b>HYDRAULIC: COMMON TO ALL UNITS</b>	
BARNES 24V DOWN SOLENOID COIL	015-301
BARNES 115V DOWN SOLENOID COIL	001-741
BARNES 24V/115V DOWN SOLENOID VALVE	003-106
RELIEF VALVE	001-263
SUCTION LINE FILTER	001-280
<b>TRANSFORMER: SELECT BY VOLTAGE AND OPTIONS</b>	
115/230V 3PH TRANSFORMER	029-921
230V/460V 3PH TRANSFORMER	029-919
<b>CONTACTOR/MOTOR STARTER:</b>	
115V 1PH TESYS CONTACTOR	000-692
230V 1PH TESYS CONTACTOR	000-692
230V 3PH TESYS CONTACTOR	000-692
460V 3PH TESYS CONTACTOR	000-692
<b>OVERLOAD:</b>	
115V 1PH TESYS OVERLOAD	000-700
230V 1PH TESYS OVERLOAD	000-698
230V 3PH TESYS OVERLOAD	000-699
460V 3PH TESYS OVERLOAD	000-696
<b>OPTIONS:</b>	
BLUE SPRAY PAINT 16oz	015-173
YELLOW SPRAY PAINT 16oz	015-174
PUSH BUTTON	000-802
REPLACEMENT NAME/SERIAL TAG	001-448

**TO ORDER PARTS CALL 800-843-3625**  
**OR E-MAIL [PARTS@ADVANCELIFTS.COM](mailto:PARTS@ADVANCELIFTS.COM)**



# SAFETY DATA SHEET



Dual Range HV 46

## Section 1. Identification

GHS product identifier  
Dual Range HV 46  
Product code  
460278-CA01  
SDS #  
460278

Relevant identified uses of the substance or mixture and uses advised against

Use of the substance/  
mixture  
Hydraulic fluid.  
For specific application advice see appropriate Technical Data Sheet or consult our company representative.

### Manufacturer

BP Lubricants USA Inc.  
1500 Valley Road  
Wayne, NJ 07470  
Telephone: +1-888-CASTROL  
Product Information: +1-877-641-1600

### Supplier

Wakefield Canada Inc.  
3620 Lakeshore Blvd West  
Toronto, Ontario, Canada M8W 1P2  
Phone Number - 416-252-5511  
+1-800-447-8735

### EMERGENCY HEALTH

#### INFORMATION:

EMERGENCY TELEPHONE  
NUMBER  
1 (613) 996-6666 CANUTEC (Canada)  
+1-800-424-9300 (CHEMTREC USA)  
+1-703-527-3887 (CHEMTREC outside the US)

## Section 2. Hazard identification

Classification of the  
substance or mixture

Not classified.

### GHS label elements

#### Signal word

No signal word.

#### Hazard statements

No known significant effects or critical hazards.

#### Precautionary statements

Not applicable.

#### Prevention

Not applicable.

#### Response

Not applicable.

#### Storage

Not applicable.

#### Disposal

Not applicable.

#### Other hazards which do not

#### result in classification

Deletting to the skin.  
Note: High Pressure Applications  
injections through the skin resulting from contact with the product at high pressure  
constitute a major medical emergency.  
See 'Notes to physician' under First-Aid Measures, Section 4 of this Safety Data  
Sheet.

## Section 3. Composition/information on ingredients

Substance/mixture

Mixture

Ingredient name	CAS number	% (w/w)
Base oil - highly refined	Varies - See Key to abbreviations	≥90
Base oil - highly refined	Varies - See Key to abbreviations	≤3

There are no additional ingredients present which, within the current knowledge of the supplier and in the concentrations applicable, are classified as hazardous to health and hence require reporting in this section.

Occupational exposure limits, if available, are listed in Section 8.

## Section 4. First-aid measures

### Description of necessary first-aid measures

**Eye contact**  
In case of contact, immediately flush eyes with plenty of water for at least 15 minutes. Eyelids should be held away from the eyeball to ensure thorough rinsing. Check for and remove any contact lenses. Get medical attention.

### Skin contact

Wash skin thoroughly with soap and water or use recognized skin cleanser. Remove contaminated clothing and shoes. Wash clothing before reuse. Clean shoes thoroughly before reuse. Get medical attention if symptoms occur.

### Inhalation

If inhaled, remove to fresh air. Get medical attention if symptoms occur.

### Ingestion

Do not induce vomiting unless directed to do so by medical personnel. Get medical attention if symptoms occur.

### Protection of first-aiders

No action shall be taken involving any personal risk or without suitable training.

### Most important symptoms/effects, acute and delayed

See Section 11 for more detailed information on health effects and symptoms.

### Indication of immediate medical attention and special treatment needed, if necessary

Notes to physician  
Treatment should in general be symptomatic and directed to relieving any effects

Note: High Pressure Applications  
injections through the skin resulting from contact with the product at high pressure constitute a major medical emergency. Injuries may not appear serious at first but within a few hours tissue becomes swollen, discolored and extremely painful with extensive subcutaneous necrosis.

Surgical exploration should be undertaken without delay. Thorough and extensive debridement of the wound and underlying tissue is necessary to minimize tissue loss and prevent or limit permanent damage. Note that high pressure may force the product considerable distances along tissue planes.

### Specific treatments

No specific treatment.

## Section 5. Fire-fighting measures

### Extinguishing media

Suitable extinguishing media  
In case of fire, use foam, dry chemical or carbon dioxide extinguisher or spray.

### Unsuitable extinguishing media

Do not use water jet.

### Specific hazards arising from the chemical

In a fire or if heated, a pressure increase will occur and the container may burst.

### Hazardous thermal decomposition products

Combustion products may include the following:  
carbon oxides (CO, CO<sub>2</sub>) (carbon monoxide, carbon dioxide)

Product name Dual Range HV 46  
Version 2.03

Date of issue 10/30/2017.

Product code 460278-CA01  
Format Canada

(Canada)

Page: 1/9  
Language ENGLISH  
(ENGLISH)

Product code 460278-CA01  
Format Canada

(Canada)

Page: 2/9  
Language ENGLISH  
(ENGLISH)

## Section 5. Fire-fighting measures

**Special protective actions for fire-fighters**  
Promptly isolate the scene by removing all persons from the vicinity of the incident if there is a fire. No action shall be taken involving any personal risk or without suitable training.

**Special protective equipment for fire-fighters**  
Fire-fighters should wear positive pressure self-contained breathing apparatus (SCBA) and full turnout gear.

## Section 6. Accidental release measures

### **Personal precautions, protective equipment and emergency procedures**

**For non-emergency personnel**  
No action shall be taken involving any personal risk or without suitable training. Evacuate surrounding areas. Keep unnecessary and unprotected personnel from entering. Do not touch or walk through spilled material. Put on appropriate personal protective equipment. Floors may be slippery; use care to avoid falling.

**For emergency responders**  
If specialized clothing is required to deal with the spillage, take note of any information in Section 8 on suitable and unsuitable materials. See also the information in "For non-emergency personnel".

**Environmental precautions**  
Avoid dispersal of spilled material and runoff and contact with soil, waterways, drains and sewers. Inform the relevant authorities if the product has caused environmental pollution (sewers, waterways, soil or air).

### **Methods and materials for containment and cleaning up**

**Small spill**  
Stop leak if without risk. Move containers from spill area. Absorb with an inert material and place in an appropriate waste disposal container. Dispose of via a licensed waste disposal contractor.

**Large spill**  
Stop leak if without risk. Move containers from spill area. Prevent entry into sewers, water courses, basements or confined areas. Contain and collect spillage with non-combustible, absorbent material (e.g. sand, earth, vermiculite or diatomaceous earth) and place in container for disposal according to local regulations. Dispose of via a licensed waste disposal contractor.

## Section 7. Handling and storage

### **Precautions for safe handling**

Put on appropriate personal protective equipment (see Section 8).

**Advice on general occupational hygiene**  
Eating, drinking and smoking should be prohibited in areas where this material is handled, stored and processed. Wash thoroughly after handling. Remove contaminated clothing and protective equipment before entering eating areas. See also Section 8 for additional information on hygiene measures.

**Conditions for safe storage, including any incompatibilities**  
Store in accordance with local regulations. Store in original container protected from direct sunlight in a dry, cool and well-ventilated area, away from incompatible materials (see Section 10) and food and drink. Keep container tightly closed and sealed until ready for use. Store and use only in equipment/containers designed for use with this product. Containers that have been opened must be carefully resealed and kept upright to prevent leakage. Do not store in unlabeled containers. Use appropriate containment to avoid environmental contamination.

## Section 8. Exposure controls/personal protection

### **Control parameters**

#### **Occupational exposure limits**

Ingredient name	Exposure limits
Base oil - highly refined	<b>CA Alberta Provincial (Canada)</b> 15 min OEL: 10 mg/m <sup>3</sup> 15 minutes. Issued/Revised: 7/2009 Form: Mist 8 hrs OEL: 5 mg/m <sup>3</sup> 8 hours. Issued/Revised: 4/2004 Form: Mist <b>CA Quebec Provincial (Canada)</b> STEV: 10 mg/m <sup>3</sup> 15 minutes. Issued/Revised: 1/2000 Form: mist TWAEV: 5 mg/m <sup>3</sup> 8 hours. Issued/Revised: 1/2000

Product name Dual Range HV 46  
Version 2.03  
Date of issue 10/30/2017.  
Product code 460278-CA01  
Format Canada  
(Canada)  
Language ENGLISH  
(ENGLISH)  
Page: 3/9

## Section 8. Exposure controls/personal protection

Base oil - highly refined	Form: mist
	<b>CA Alberta Provincial (Canada)</b> 15 min OEL: 10 mg/m <sup>3</sup> 15 minutes. Issued/Revised: 7/2009 Form: Mist 8 hrs OEL: 5 mg/m <sup>3</sup> 8 hours. Issued/Revised: 4/2004 Form: Mist <b>CA Quebec Provincial (Canada)</b> STEV: 10 mg/m <sup>3</sup> 15 minutes. Issued/Revised: 1/2000 Form: mist TWAEV: 5 mg/m <sup>3</sup> 8 hours. Issued/Revised: 1/2000 Form: mist

### **Appropriate engineering controls**

All activities involving chemicals should be assessed for their risks to health, to ensure exposures are adequately controlled. Personal protective equipment should only be considered after other forms of control measures (e.g. engineering controls) have been suitably evaluated. Personal protective equipment should conform to appropriate standards, be suitable for use, be kept in good condition and properly maintained.

Your supplier of personal protective equipment should be consulted for advice on selection and appropriate standards. For further information contact your national organisation for standards.

Provide exhaust ventilation or other engineering controls to keep the relevant airborne concentrations below their respective occupational exposure limits.

The final choice of protective equipment will depend upon a risk assessment. It is important to ensure that all items of personal protective equipment are compatible. Emissions from ventilation or work process equipment should be checked to ensure they comply with the requirements of environmental protection legislation. In some cases, fume scrubbers, filters or engineering modifications to the process equipment will be necessary to reduce emissions to acceptable levels.

### **Environmental exposure controls**

### **Individual protection measures**

#### **Hygiene measures**

Wash hands, forearms and face thoroughly after handling chemical products, before eating, smoking and using the lavatory and at the end of the working period. Appropriate techniques should be used to remove potentially contaminated clothing. Wash contaminated clothing before reusing. Ensure that eyewash stations and safety showers are close to the workstation location.

#### **Eye/face protection**

#### **Skin protection**

#### **Hand protection**

Wear protective gloves if prolonged or repeated contact is likely. Wear chemical resistant gloves. Recommended: Nitrile gloves. The correct choice of protective gloves depends upon the chemicals being handled, the conditions of work and use, and the condition of the gloves (even the best chemically resistant glove will break down after repeated chemical exposures). Most gloves provide only a short time of protection before they must be discarded and replaced. Because specific work environments and material handling practices vary, safety procedures should be developed for each intended application. Gloves should therefore be chosen in consultation with the supplier/manufacturer and with a full assessment of the working conditions.

#### **Body protection**

Use of protective clothing is good industrial practice. Personal protective equipment for the body should be selected based on the task being performed and the risks involved and should be approved by a specialist handling this product. Cotton or polyester/cotton overalls will only provide protection against light superficial contamination that will not soak through to the skin. Overalls should be laundered on a regular basis. When the risk of skin exposure is high (e.g. when cleaning up spillages or if there is a risk of splashing) then chemical resistant aprons and/or impermeous chemical suits and boots will be required.

Product name Dual Range HV 46  
Version 2.03  
Date of issue 10/30/2017.  
Product code 460278-CA01  
Format Canada  
(Canada)  
Language ENGLISH  
(ENGLISH)  
Page: 4/9

## Section 8. Exposure controls/personal protection

### Other skin protection

Appropriate footwear and any additional skin protection measures should be selected based on the task being performed and the risks involved and should be approved by a specialist before handling this product.

### Respiratory protection

In case of insufficient ventilation, wear suitable respiratory equipment. The correct choice of respiratory protection depends upon the chemicals being handled, the conditions of work and use, and the condition of the respiratory equipment. Safety procedures should be developed for each intended application. Respiratory protection equipment should therefore be chosen in consultation with the supplier/manufacturer and with a full assessment of the working conditions.

## Section 9. Physical and chemical properties

### Appearance

Physical state	Liquid.
Color	Purple.
Odor	Not available.
Odor threshold	Not available.
pH	Not available.
Melting point	Not available.
Boiling point	Not available.
Flash point	Closed cup: >190°C (>374°F) [Pensky-Martens.]
Pour point	-42 °C
Drop Point	Not available.
Evaporation rate	Not available.
Flammability (solid, gas)	Not applicable. Based on - Physical state
Lower and upper explosive (flammable) limits	Not available.
Vapor pressure	Not available.
Vapor density	Not available.
Density	<1000 kg/m <sup>3</sup> (<1 g/cm <sup>3</sup> ) at 15 °C
Relative density	Not available.
Solubility	insoluble in water.
Partition coefficient: n-octanol/water	Not available.
Auto-ignition temperature	Not available.
Decomposition temperature	Not available.
Viscosity	Kinematic: 45.9 mm <sup>2</sup> /s (45.9 cSt) at 40°C Kinematic: 8.15 mm <sup>2</sup> /s (8.15 cSt) at 100°C

## Section 10. Stability and reactivity

**Reactivity** No specific test data available for this product. Refer to Conditions to avoid and incompatible materials for additional information.

**Chemical stability** The product is stable.

**Possibility of hazardous reactions** Under normal conditions of storage and use, hazardous reactions will not occur. Under normal conditions of storage and use, hazardous polymerization will not occur.

**Conditions to avoid** Avoid all possible sources of ignition (spark or flame).

**Incompatible materials** Reactive or incompatible with the following materials: oxidizing materials.

## Section 10. Stability and reactivity

**Hazardous decomposition** Under normal conditions of storage and use, hazardous decomposition products should not be produced.

## Section 11. Toxicological information

### Information on toxicological effects

#### Aspiration hazard

Name	Result
Base oil - highly refined	ASPIRATION HAZARD - Category 1

Routes of entry anticipated: Dermal, Inhalation.

#### Potential acute health effects

**Eye contact** No known significant effects or critical hazards.  
**Skin contact** Defatting to the skin. May cause skin dryness and irritation.  
**Inhalation** Vapor inhalation under ambient conditions is not normally a problem due to low vapor pressure.

**Ingestion** No known significant effects or critical hazards.

#### Symptoms related to the physical, chemical and toxicological characteristics

**Eye contact** No specific data.  
**Inhalation** No specific data.  
**Skin contact** Adverse symptoms may include the following: irritation, dryness, cracking

**Ingestion** No specific data.

#### Delayed and immediate effects and also chronic effects from short and long term exposure

**Short term exposure** Not available.

**Potential immediate effects** Not available.

**Potential delayed effects** Not available.

**Long term exposure** Not available.

**Potential immediate effects** Not available.

**Potential delayed effects** Not available.

#### Potential chronic health effects

**General** No known significant effects or critical hazards.  
**Carcinogenicity** No known significant effects or critical hazards.  
**Mutagenicity** No known significant effects or critical hazards.  
**Teratogenicity** No known significant effects or critical hazards.  
**Developmental effects** No known significant effects or critical hazards.  
**Fertility effects** No known significant effects or critical hazards.

#### Numerical measures of toxicity

#### Acute toxicity estimates

Not available.

## Section 12. Ecological information

### Toxicity

No testing has been performed by the manufacturer.

### Persistence and degradability

Expected to be biodegradable.

### Bioaccumulative potential

This product is not expected to bioaccumulate through food chains in the environment.

### Mobility in soil

Soil/water partition

coefficient ( $K_{ow}$ )

Mobility

Not available.

Spillages may penetrate the soil causing ground water contamination.

### Other ecological information

Spills may form a film on water surfaces causing physical damage to organisms.  
Oxygen transfer could also be impaired.

## Section 13. Disposal considerations

### Disposal methods

The generation of waste should be avoided or minimized wherever possible. Significant quantities of waste product residues should not be disposed of via the foul sewer but processed in a suitable effluent treatment plant. Dispose of surplus and non-recyclable products via a licensed waste disposal contractor. Disposal of this product, solutions and any by-products should at all times comply with the requirements of environmental protection and waste disposal legislation and any regional local authority requirements. Waste packaging should be recycled. Incineration or landfill should only be considered when recycling is not feasible. This material and its container must be disposed of in a safe way. Empty containers or liners may retain some product residues. Avoid dispersal of spilled material and runoff and contact with soil, waterways, drains and sewers.

## Section 14. Transport information

	<b>DOT Classification</b>	<b>TDG Classification</b>	<b>IMDG</b>	<b>IATA</b>
<b>UN number</b>	Not regulated.	Not regulated.	Not regulated.	Not regulated.
<b>UN proper shipping name</b>	-	-	-	-
<b>Transport hazard class(es)</b>	-	-	-	-
<b>Packing group</b>	-	-	-	-
<b>Environmental hazards</b>	No.	No.	No.	No.
<b>Additional information</b>	-	-	-	-

### Special precautions for user

Not available.

## Section 14. Transport information

Not available.

Transport in bulk according to Annex II of MARPOL and the IBC Code

## Section 15. Regulatory information

### Other regulations

Australia Inventory (AICS)

All components are listed or exempted.

Canada Inventory

All components are listed or exempted.

China Inventory (IECSC)

All components are listed or exempted.

Japan Inventory (JENCS)

All components are listed or exempted.

Korea Inventory (KECI)

All components are listed or exempted.

Philippines Inventory (PICCS)

All components are listed or exempted.

Taiwan Chemical Substances Inventory (TCSI)

Not determined.

United States Inventory (TSCA 8b)

All components are listed or exempted.

REACH Status

All components are listed or exempted.

For the REACH status of this product please consult your company contact, as identified in Section 1.

## Section 16. Other information

### History

Date of issue/Date of revision

30/10/2017

Date of previous issue

06/01/2017.

Version

2.03

Prepared by

Product Stewardship

Key to abbreviations

ATE = Acute Toxicity Estimate

BCF = Bioconcentration Factor

CAS Number = Chemical Abstracts Service Registry Number

GHS = Globally Harmonized System of Classification and Labelling of Chemicals

HPR = Hazardous Products Regulations

IATA = International Air Transport Association

IBC = Intermediate Bulk Container

IMDG = International Maritime Dangerous Goods

LogPow = logarithm of the octanol/water partition coefficient

MARPOL = International Convention for the Prevention of Pollution From Ships, 1973 as modified by the Protocol of 1978. ("Marpol" = marine pollution)

REACH = Registration, Evaluation, Authorisation and Restriction of Chemicals Regulation [Regulation (EC) No. 1907/2006]

UN = United Nations

Varies = may contain one or more of the following

101316-71-6, 101316-72-7, 64741-88-4, 64741-89-5, 64741-96-3, 64741-96-4, 64741-97-5, 64742-01-4, 64742-44-5, 64742-45-6, 64742-52-5, 64742-53-6, 64742-54-7, 64742-55-8, 64742-56-9, 64742-57-0, 64742-58-1, 64742-62-7, 64742-63-8, 64742-64-9, 64742-65-0, 64742-70-7, 72623-85-9, 72623-86-0, 72623-87-1, 74869-22-0, 90669-74-2

Not available.

Indicates information that has changed from previously issued version.

Notice to reader

## Section 12. Ecological information

### Toxicity

No testing has been performed by the manufacturer.

### Persistence and degradability

Expected to be biodegradable.

### Bioaccumulative potential

This product is not expected to bioaccumulate through food chains in the environment.

### Mobility in soil

Soil/water partition

coefficient ( $K_{ow}$ )

Mobility

Not available.

Spillages may penetrate the soil causing ground water contamination.

### Other ecological information

Spills may form a film on water surfaces causing physical damage to organisms.  
Oxygen transfer could also be impaired.

## Section 13. Disposal considerations

### Disposal methods

The generation of waste should be avoided or minimized wherever possible. Significant quantities of waste product residues should not be disposed of via the foul sewer but processed in a suitable effluent treatment plant. Dispose of surplus and non-recyclable products via a licensed waste disposal contractor. Disposal of this product, solutions and any by-products should at all times comply with the requirements of environmental protection and waste disposal legislation and any regional local authority requirements. Waste packaging should be recycled. Incineration or landfill should only be considered when recycling is not feasible. This material and its container must be disposed of in a safe way. Empty containers or liners may retain some product residues. Avoid dispersal of spilled material and runoff and contact with soil, waterways, drains and sewers.

## Section 14. Transport information

	<b>DOT Classification</b>	<b>TDG Classification</b>	<b>IMDG</b>	<b>IATA</b>
<b>UN number</b>	Not regulated.	Not regulated.	Not regulated.	Not regulated.
<b>UN proper shipping name</b>	-	-	-	-
<b>Transport hazard class(es)</b>	-	-	-	-
<b>Packing group</b>	-	-	-	-
<b>Environmental hazards</b>	No.	No.	No.	No.
<b>Additional information</b>	-	-	-	-

### Special precautions for user

Not available.

## Section 16. Other information

All reasonably practicable steps have been taken to ensure this data sheet and the health, safety and environmental information contained in it is accurate as of the date specified below. No warranty or representation, express or implied is made as to the accuracy or completeness of the data and information in this data sheet.

The data and advice given apply when the product is sold for the stated application or applications. You should not use the product other than for the stated application or applications without seeking advice from BP Group.

It is the user's obligation to evaluate and use this product safely and to comply with all applicable laws and regulations. The BP Group shall not be responsible for any damage or injury resulting from use, other than the stated product use of the material, from any failure to adhere to recommendations, or from any hazards inherent in the nature of the material. Purchasers of the product for supply to a third party for use at work, have a duty to take all necessary steps to ensure that any person handling or using the product is provided with the information in this sheet. Employers have a duty to tell employees and others who may be affected of any hazards described in this sheet and of any precautions that should be taken. You can contact the BP Group to ensure that this document is the most current available. Alteration of this document is strictly prohibited.

