

HYDRAULIC DIAGRAM

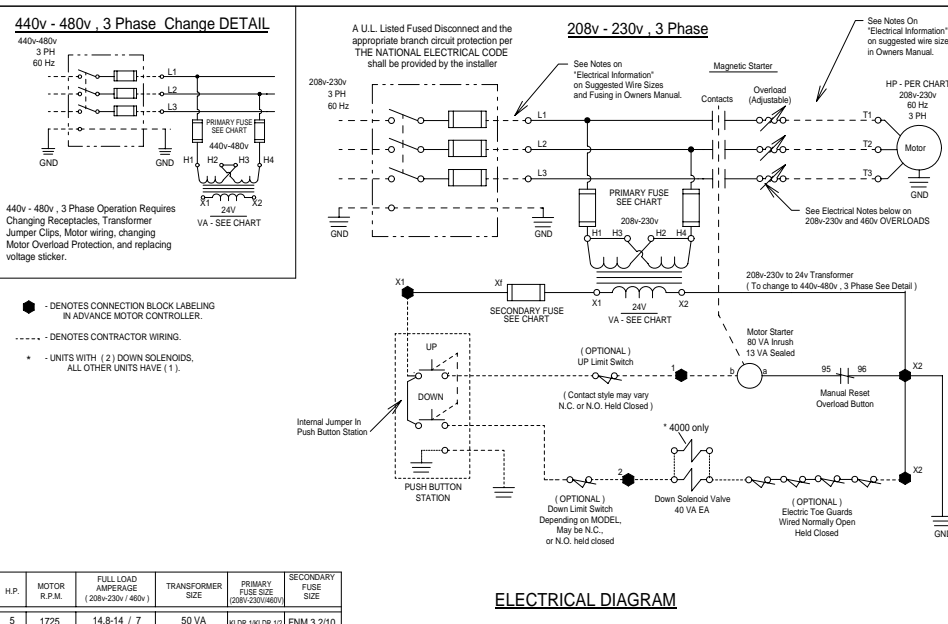

ELECTRICAL DIAGRAM

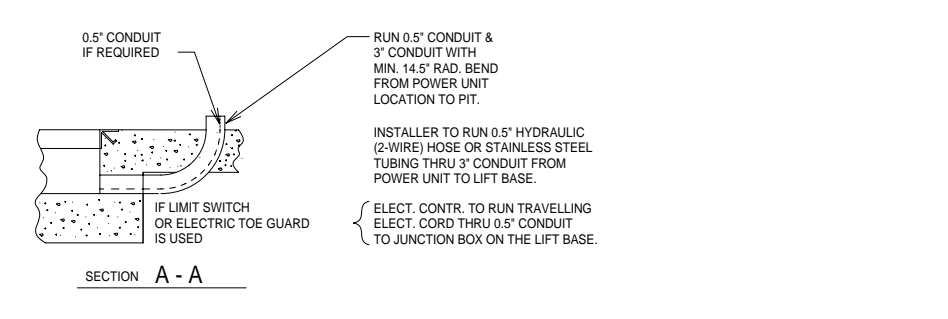

- GENERAL NOTES:**
- ALL AXLES AND SHAFTS ARE CHROME PLATED.
 - ALL ROLLERS AND PIVOT POINTS ARE EQUIPPED WITH TEFLON SELF-LUBRICATING BEARINGS.
 - ADVANCE LIFTS, INC. TO SUPPLY 5 GALLONS OF A MULTI VISCOSITY ISO-46 GROUP II BASE OIL & (1) 20' .5" EXTRA HEAVY DOUBLE WIRE BRAID HOSE (SAE 100R2) FOR THE POWER UNIT TO THE EQUIPMENT CONNECTION WITH .5" JIC FEMALE SWIVEL FITTINGS ON THE ENDS.
 - REINFORCE CONCRETE TO SUIT LOCAL SOIL CONDITIONS PLUS YOUR DESIRED SAFETY FACTORS.
 - OVERALL POWER UNIT SIZE: 26" WIDE X 12" LONG X 15" HIGH (INCLUDING MOTOR, AND BRACKETS FOR FLOOR MOUNTING).
 - CONCRETE WORK, REINFORCING, BUILDING MODIFICATIONS, PIPING, ELECTRICAL WIRING, EMBEDDED ITEMS, INSTALLATION, ETC. (BY OTHERS)
 - ADVANCE LIFTS, INC. TO SUPPLY:
 - (1) 20' LG. PUSHBUTTON COILCORD.
 - 20' FEET OF .25" I.D. HYDRAULIC HOSE WITH .25" FEMALE JIC SWIVEL FITTINGS ON THE ENDS FOR THE VENT LINE CONNECTION FROM THE BASEFRAME TO THE POWER UNIT.
 - INSTALLATION PACKAGE AS OUTLINED IN GENERAL NOTE #3.
 - FINISH: BLUE PAINT
 - PIT DIMENSION TOLERANCES ARE PLUS .25", MINUS 0" (+.25", -0").

- SPECIFICATIONS:**
- CAPACITY : 5,000 LBS MAX. LIFTING CAPACITY
2,500 LBS MAX. AXLE CAPACITY ENDS
2,500 LBS MAX. AXLE CAPACITY SIDES
- PLATFORM : 96" WIDE X 120" LONG
SAFETY TREAD DECK
REMOVABLE HANDRAILS - STEEL
BRIDGE: 12" LONG X 72" WIDE,
SOLID STEEL BRIDGE
ALL WITH CHAINS
BEVEL TOE GUARDS
SAFETY STRIPING
- SPEED : 10 FPM
- TRAVEL : 58" (FROM A 8" LOWERED HEIGHT)
- LOWERED HEIGHT : 8"
- POWER UNIT : 5 HP MOTOR 230 V 60 Hz 3PH
(REMOTE FROM LIFT)
- CONTROLS: UP-DOWN WEATHER-PROOF PUSHBUTTON STATION, PENDANT TYPE NEMA 1, 3, 3R, 4, 4X.
- IN NEMA 12 ENCLOSURE : MAGNETIC STARTER, W/ OVERLOAD
230 V TO 24 V CONTROL TRANSFORMER,
- APPROXIMATE SHIPPING WEIGHT: 3,100 LBS
- ALL DIMENSIONS ARE IN INCHES UNLESS OTHERWISE NOTED.

ADVANCE LIFTS
Advance Lifts, Inc. 701 S. Kirk Rd.
St. Charles, IL 60174
Phone: 630-584-9881 Fax: 630-584-9405

JOB NUMBER: _____

SCALE: N.T.S. REVISIONS: _____ BY: _____ DATE: _____

DRN: _____ DWD: _____

APVD: _____

TITLE: SUPERDOK SERIES T-50810 NO. _____ REV. _____