

- GENERAL NOTES:**
- ALL AXLES AND SHAFTS ARE CHROME PLATED.
 - ALL ROLLERS AND PIVOT POINTS ARE EQUIPPED WITH TEFLON SELF-LUBRICATING BEARINGS.
 - POWER UNIT EQUIPPED WITH ONE PIECE "ADVANCE FLOW" VALVE MANIFOLD.
 - 3" VERTICAL AND 4" HORIZONTAL TOE CLEARANCE 3-SIDES.
 - ADVANCE LIFTS, INC. TO SUPPLY:
 - PREWIRED W/(1) 15' LG. POWER CORD (FROM POWER UNIT TO PLUG)

VOLTAGE	*PLUG BY ADVANCE	*RECEPTACLE BY CUSTOMER
115V 1 PHASE	NEMA LS-30P	NEMA LS-30R

- SPECIFICATIONS:**
- CAPACITY :** 4,000 LBS MAX. LIFTING CAPACITY
2,000 LBS MAX. AXLE CAPACITY ENDS
2,000 LBS MAX. AXLE CAPACITY SIDES
- PLATFORM :** 72" X 73.5",
SAFETY TREAD DECK
REMOVABLE HANDRAILS - STEEL
18" X 60" STEEL HINGED BRIDGE WITH CHAIN
30" X 60" CHOCK RAMP- STEEL
SAFETY CHAIN
- SPEED :** 10 FPM UP
TRAVEL : 53" (FROM A 5.25" LOWERED HEIGHT)
LOWERED HEIGHT : 5.25"
POWER UNIT : 2 HP MOTOR 115V 60 Hz 1 PH
SELF-CONTAINED AND PREWIRED
- CONTROL :** UP-DOWN WEATHER-PROOF PUSHBUTTON STATION ON CORD, PENDANT TYPE NEMA 1, 3, 3R, 4, 4X.
IN NEMA 12 ENCLOSURE : MAGNETIC STARTER, W/ OVERLOAD 115V TO 24 V CONTROL TRANSFORMER.
- FINISH:** BLUE
OTHERS: FIXED CASTERS-ONE END
WHEEL DOLLY-OTHER END
APPROXIMATE SHIPPING WEIGHT : #2,400

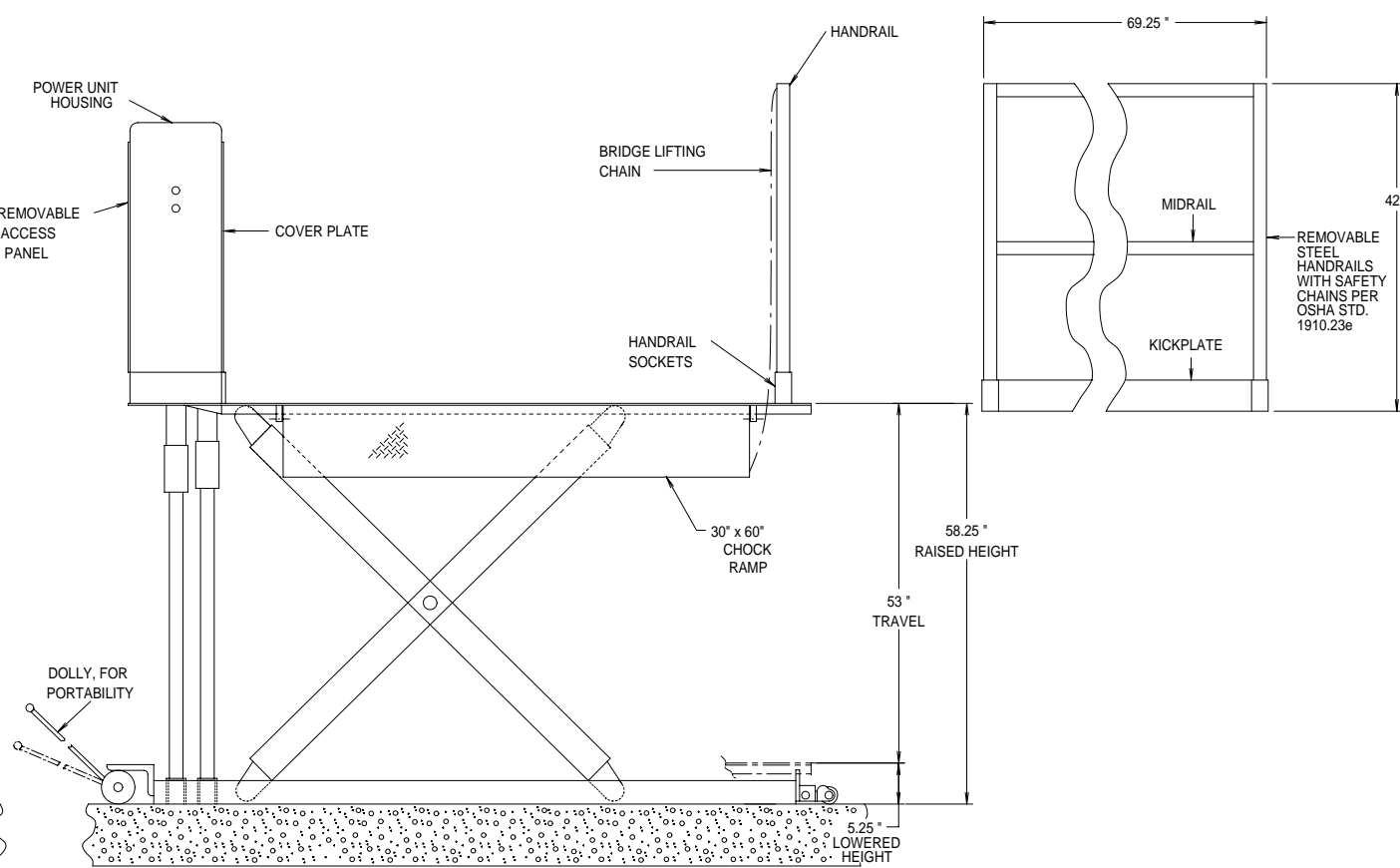
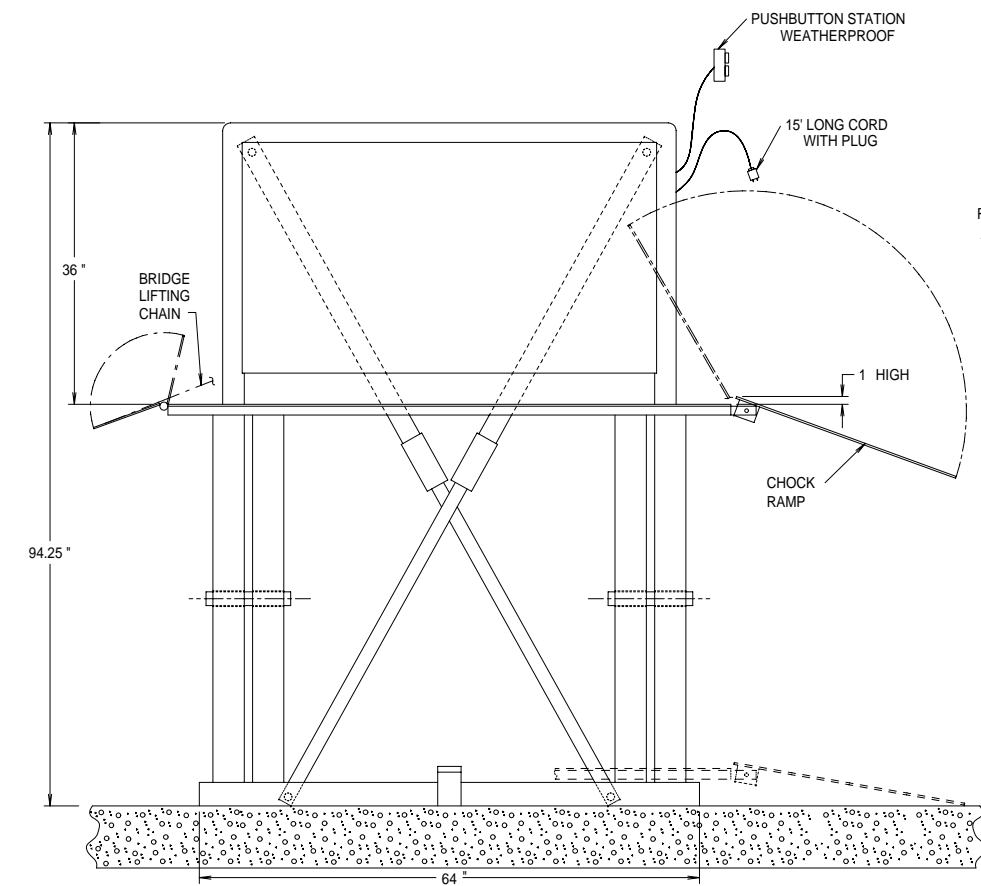

DO NOT SCALE DRAWING

ADVANCE LIFTS		Advance Lifts, Inc. S. 701 Kirk Rd. St. Charles, IL 60174 Phone: 630-584-9881 Fax: 630-584-9405	
JOB NAME:	X	REVISIONS	BY DATE
JOB NUMBER:	X		
SCALE:	X		
DATE:	X		
DWN:	X		
APVD:			
TITLE:	SUPERDOK LIFT MODEL 1045	NO.:	D-
		REV.:	