

- GENERAL NOTES:**
- ALL AXLES AND SHAFTS ARE CHROME PLATED.
 - ALL ROLLERS AND PIVOT POINTS ARE EQUIPPED WITH TEFLON SELF-LUBRICATING BEARINGS.
 - INSTALLER TO SUPPLY APPROXIMATELY 15 GALLONS OF A MULTI-VISCOSITY ISO-46 GROUP II BASE OIL & (2) 20' 5" EXTRA HEAVY DOUBLE WIRE BRAID HOSES (SAE 100R2) FOR THE POWER UNIT TO THE EQUIPMENT CONNECTION WITH 5" JIC FEMALE FITTINGS ON THE ENDS.
 - REINFORCE CONCRETE TO SUIT LOCAL SOIL CONDITIONS PLUS YOUR DESIRED SAFETY FACTORS.
 - OVERALL POWER UNIT SIZE: 28" WIDE X 22" LONG X 21" HIGH (INCLUDING MOTOR, AND BRACKETS FOR WALL MOUNTING).
 - CONCRETE WORK, REINFORCING, BUILDING MODIFICATIONS, PIPING, ELECTRICAL WIRING, EMBEDDED ITEMS, INSTALLATION, ETC. (BY OTHERS)
 - ADVANCE LIFTS, INC. TO SUPPLY:
 - (1) 20' LG. PUSHBUTTON COIL CORD.
 - (2) LENGTH OF .25 O.D. CLEAR POLYURETHANE TUBING FOR THE VENT LINES.
 - FINISH: BLUE PAINT
 - PIT DIMENSION TOLERANCES ARE PLUS .25" MINUS 0" (+.25" - 0").

- SPECIFICATIONS:**
- CAPACITY :** 20,000 LBS MAX. LIFTING CAPACITY
16,000 LBS MAX. AXLE CAPACITY ENDS
14,000 LBS MAX. AXLE CAPACITY SIDES
- PLATFORM :** 84" X 144",
SAFETY TREAD DECK,
REMOVABLE HANDRAILS - STEEL
12" X 7" STEEL BRIDGE WITH CHAIN
BEVEL TOE GUARDS
- SPEED :** 8 FPM
- TRAVEL :** 59" (FROM A 20" LOWERED HEIGHT)
- LOWERED HEIGHT :** 20"
- POWER UNIT :** 7.5 HP MOTOR 230 V 60 Hz SPH
(REMOTE FROM LIFT)
- CONTROL :** UP-DOWN WEATHER-PROOF PUSHBUTTON
STATION, PENDANT TYPE NEMA 1, 3, 3R, 4, 4X.
- IN NEMA 12 ENCLOSURE :** MAGNETIC STARTER, W/ OVERLOAD
230 V TO 24 V CONTROL TRANSFORMER.
- APPROXIMATE SHIPPING WEIGHT:** #7,500

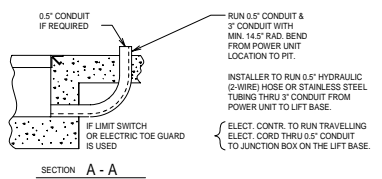
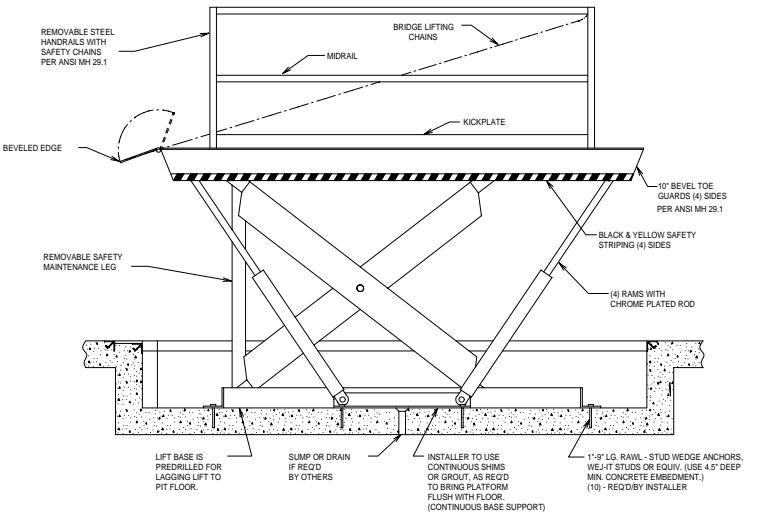
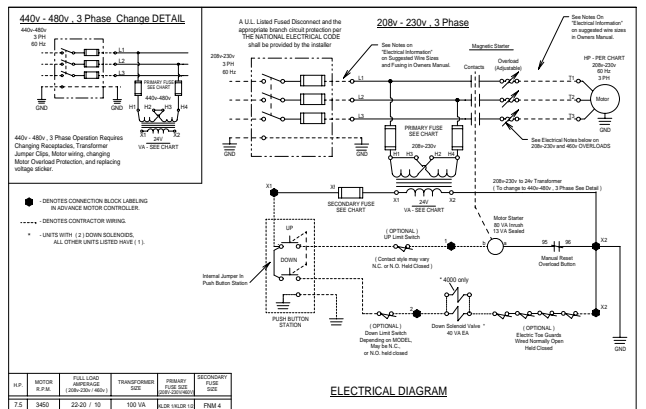
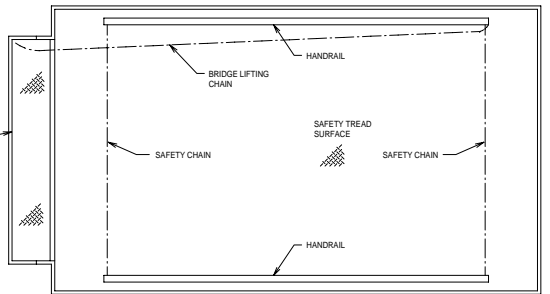

00-NOT SCALE DRAWING

ADVANCE LIFTS		Advance Lifts, Inc. 701 S. KVA Rd St. Charles, IL 60174 Phone: 630-684-9881 Fax: 630-684-9426	
JOB NAME	X	NO.	REV.
JOB NUMBER	X		
SCALE	1" = 1'-0"	REVISIONS	BY DATE
DRAWN	X		
CHECKED	X		
DATE	X		
TITLE	SUPERDOK MODEL 4450		