

HYDRAULIC DIAGRAM

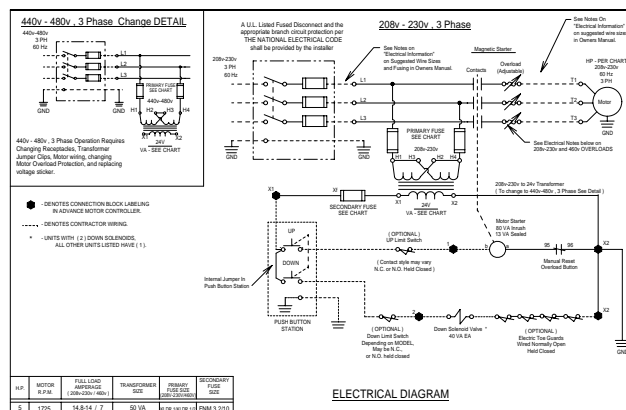

ELECTRICAL DIAGRAM

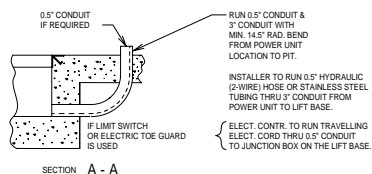

GENERAL NOTES:

1. ALL AXLES AND SHAFTS ARE CHROME PLATED.
2. ALL ROLLERS AND PIVOT POINTS ARE EQUIPPED WITH TEFLON SELF-LUBRICATING BEARINGS.
3. INSTALLER TO SUPPLY APPROXIMATELY 15 GALLONS OF A MULTI-VISCOSITY ISO-46 GROUP II BASE OIL & (2) 20' 5" EXTRA HEAVY DOUBLE WIRE BRAID HOSES (SAE 100R2) FOR THE POWER UNIT TO THE EQUIPMENT CONNECTION WITH 5" JIC FEMALE FITTINGS ON THE ENDS.
4. REINFORCE CONCRETE TO SUIT LOCAL SOIL CONDITIONS PLUS YOUR DESIRED SAFETY FACTORS.
5. OVERALL POWER UNIT SIZE: 26" WIDE X 22" LONG X 21" HIGH (INCLUDING MOTOR, AND BRACKETS FOR WALL MOUNTING).
6. CONCRETE WORK, REINFORCING, BUILDING MODIFICATIONS, PIPING, ELECTRICAL WIRING, EMBEDDED ITEMS, INSTALLATION, ETC. (BY OTHERS)
7. ADVANCE LIFTS, INC. TO SUPPLY:
 - (1) 20' LG. PUSHBUTTON COIL CORD.
 - 20' LENGTH OF 25 O.D. CLEAR POLYURETHANE TUBING FOR THE VENT LINES.
8. FINISH: BLUE PAINT
9. PIT DIMENSION TOLERANCES ARE PLUS .25", MINUS 0" (+.25" - 0").

SPECIFICATIONS:

CAPACITY : 12,000 LBS MAX. LIFTING CAPACITY
9,500 LBS MAX. AXLE CAPACITY ENDS
8,400 LBS MAX. AXLE CAPACITY SIDES

PLATFORM : 96" X 120" SAFETY TREAD DECK,
REMOVABLE HANDRAILS - STEEL
12" X 72" STEEL BRIDGE WITH CHAIN
BEVEL TOE GUARDS
SAFETY STRIPING

SPEED : 8 FPM

TRAVEL : 56" (FROM A 16.5" LOWERED HEIGHT)

LOWERED HEIGHT : 16.5"

POWER UNIT : 5 HP MOTOR 230 V 60 Hz 3PH
(REMOTE FROM LIFT)

CONTROL : UP-DOWN WEATHER-PROOF PUSHBUTTON
STATION, PENDANT TYPE NEMA 1, 3, 3R, 4, 4X.

IN NEMA 12 ENCLOSURE : MAGNETIC STARTER, W/ OVERLOAD
230 V TO 24 V CONTROL TRANSFORMER,

APPROXIMATE SHIPPING WEIGHT: 86,300

DO NOT SCALE DRAWING

ADVANCE LIFTS		Address: Lifts, Inc. 701 S. RIA Rd. St. Charles, IL 60174 Phone: 630.584.9881 Fax: 630.584.9405	
JOB NAME: X			
JOB NUMBER: X			
SCALE: X	REVISED:	BY:	DATE:
DATE: X			
DRN: X			
APPD:			
TITLE: SUPERDOK MODEL 4160		NO: D-	REV: 1